



Powering Business Worldwide

User's and installation guide

Eaton 93PM UPS 100–500 kVA

P-164000666



Copyright © 2018 Eaton Corporation plc. All rights reserved.

This manual contains important instructions that you should follow during installation and maintenance of the UPS and batteries. Please read all instructions before operating the equipment and save this manual for future reference.

The contents of this manual are the copyright of the publisher and may not be reproduced (even extracts) without the written approval of Eaton Corporation. Every care has been taken to ensure the accuracy of the information contained in this manual, but no liability can be accepted for any errors or omission. The right to make design modifications is reserved.

Unauthorized copying and lending are prohibited.

Eaton Power Quality Oy

Address: Koskelontie 13
FI-02920 Espoo
FINLAND

Internet: www.eaton.eu

Approvals and version history

Revision	Date	Description of change	Approved by
001	14.05.2017	First issue	Otto Asunmaa
002	28.10.2017	Second issue, to include 100 kVA	Otto Asunmaa
003	18.05.2018	Third issue, MBS added	Otto Asunmaa

Original instructions X_ / Translation of the original instructions

Contents

1	How to read this manual.....	7
1.1	Safety-related signs.....	7
1.2	Safety symbols.....	7
1.2.1	Hazard symbols.....	7
1.2.2	Prohibited action symbols.....	7
1.2.3	Mandatory action symbols.....	8
1.3	Conventions used in this document.....	8
1.4	Glossary.....	8
2	Safety instructions.....	10
2.1	Audience.....	12
2.2	CE marking.....	12
2.3	User precautions.....	12
2.4	Environment.....	13
2.5	Symbols on the UPS and accessories.....	13
2.6	For more information.....	14
3	Introduction to Eaton UPS.....	15
3.1	Looking inside the UPS system.....	16
3.2	UPS operating modes.....	20
3.2.1	Normal operating modes.....	21
3.2.2	Stored energy and battery mode.....	25
3.2.3	Bypass mode.....	27
3.3	UPS features.....	29
3.3.1	Advanced Battery Management.....	29
3.3.2	Powerware Hot Sync.....	29
3.3.3	Power Conditioner.....	30
3.3.4	Frequency Converter.....	30
3.3.5	Sync Control.....	30
3.4	Software and connectivity features.....	31
3.4.1	User interface.....	31
3.4.2	Power Management Software.....	31
3.5	Options and accessories.....	31
3.5.1	Maintenance Bypass Switch.....	31
3.5.2	Top air exhaust kit.....	31
3.5.3	Single feed kit.....	31
3.5.4	Field Installed UPM.....	32
3.6	Battery system.....	32
3.6.1	UPS Battery Switchgear.....	32
3.7	Basic system configurations.....	33

4	UPS installation plan.....	36
4.1	Creating an installation plan.....	36
4.2	Installation checklist.....	37
4.3	Site preparations.....	37
	4.3.1 Environmental and installation considerations.....	38
	4.3.2 UPS system power wiring preparations.....	43
4.4	Unpack and unload the UPS.....	49
5	UPS system installation.....	53
5.1	Steps to install the UPS.....	53
5.2	Installing the battery system.....	58
	5.2.1 Battery trip wiring.....	59
5.3	Installing UPS external battery cabinet and battery power cabling.....	60
5.4	Installing a remote EPO switch	61
5.5	Installing interface connections.....	61
	5.5.1 Installing customer input signals interface.....	62
	5.5.2 Battery breaker wiring interface.....	62
	5.5.3 Relay output interface connections.....	62
	5.5.4 Industrial Relay Card interface connections.....	63
	5.5.5 MiniSlot interface connections.....	63
	5.5.6 Installing signal interface connections in a parallel system.....	64
5.6	Wiring parallel 93PM UPS systems.....	64
	5.6.1 Power wiring overview.....	65
	5.6.2 Control signals overview.....	66
	5.6.3 Installing bypass control wiring.....	67
5.7	UPS system interface wiring preparation.....	70
6	Communication interfaces.....	72
6.1	MiniSlot cards.....	72
6.2	Intelligent Power Software.....	74
6.3	Signal input monitoring.....	75
6.4	General purpose relay contact.....	75
6.5	Configuring relays.....	76
7	UPS operating instructions.....	80
7.1	UPS controls and indicators.....	80
	7.1.1 Control panel.....	80
	7.1.2 Status indicators.....	81
	7.1.3 System events.....	83
	7.1.4 Menu structure of the 93PM UPS.....	83



7.2	Signing in.....	87
7.3	System control instructions.....	88
7.3.1	Starting the UPS system in the double conversion mode.....	88
7.3.2	Starting the UPS system in the bypass mode.....	88
7.3.3	Transferring from the bypass mode to the double conversion mode.....	89
7.3.4	Transferring from the double conversion mode to the bypass mode.....	89
7.3.5	Transferring from the double conversion mode to the Energy Saver System mode.....	90
7.3.6	Transferring from the Energy Saver System mode to the double conversion mode.....	90
7.3.7	Shutting down the UPS system and critical load.....	91
7.3.8	De-energizing the critical load.....	91
7.4	Controlling a single UPS in a parallel system.....	91
7.4.1	Starting a single UPS.....	92
7.4.2	Shutting down a single UPS.....	92
7.4.3	Enabling and disabling the battery charger.....	93
7.5	UPM control instructions.....	93
7.5.1	Starting the UPMs.....	93
7.5.2	Shutting down the UPMs.....	93
7.6	Using the Remote Emergency Power-off switch.....	94
7.7	Turning the UPS from the double conversion mode to the maintenance bypass mode.....	94
7.8	Turning the UPS from the maintenance bypass mode to the double conversion mode.....	96
8	UPS maintenance.....	99
8.1	Important safety instructions.....	99
8.2	Performing preventive maintenance.....	100
8.2.1	Daily maintenance.....	100
8.2.2	Monthly maintenance.....	100
8.2.3	Periodic maintenance.....	101
8.2.4	Annual maintenance.....	101
8.2.5	Battery maintenance.....	101
8.3	Recycling the used UPS or batteries.....	101
8.4	Maintenance training.....	102
9	Technical data.....	103
9.1	Directives and standards.....	103
9.2	UPS system input.....	104
9.3	UPS system output.....	104
9.4	UPS environmental specifications.....	105
9.5	Battery specification.....	106

10	Warranty.....	108
	10.1 General.....	108
	10.2 Whom to contact in case of Warranty.....	109
Appendix A:	Relay Alarms.....	110

1 How to read this manual

1.1 Safety-related signs

The following table explains the safety-related signs used in this document.

 DANGER	DANGER indicates a hazard with a high level of risk which, if not avoided, will result in serious injury or death.
 WARNING	WARNING indicates a hazard with a medium level of risk which, if not avoided, could result in serious injury or death, or damage to your machine.
 CAUTION	CAUTION indicates a hazard with a low level of risk which, if not avoided, could result in minor or moderate injury, or damage to your machine.







Note: Notes are used to indicate important information and useful tips.

1.2 Safety symbols



1.2.1 Hazard symbols

These symbols indicate a hazardous situation or action. Symbols are used to warn of situations, which may cause environmental damage and personal injury.

	General warning sign		Explosion and fire hazard
	Electrical hazard		Corrosive hazard
	Battery hazard		



1.2.2 Prohibited action symbols

These symbols are used to indicate an action that should not be taken.

	General symbol for prohibited action		No smoking
	Limited or restricted access		

1.2.3 Mandatory action symbols

These symbols are used to indicate an action that must be taken.

	General symbol for mandatory action		Disconnect from power source
	Read the manual or instructions		

1.3 Conventions used in this document

This document uses the following type conventions:

- **Bold type** highlights important concepts in discussions, key terms in procedures and menu options, or represents a command or option that you type or enter at a prompt.
- *Italic type* highlights notes and new terms when they are defined.
- **Screen type** represents information that appears on the screen or LCD.

1.4 Glossary

This document uses these acronyms to refer to Eaton UPS products or their parts:

Table 1: Glossary of acronyms

ABM	Advanced Battery Management
BIB	Bypass Input Breaker
EAA	Energy Advanced Architecture
EBC	External Battery Cabinet

EPO	Emergency Power-off
ESS	Energy Saver System
F-UPM	Field Installed UPM
IPM	Intelligent Power Manager
IPP	Intelligent Power Protector
MBP	Maintenance Bypass
MBS	Maintenance Bypass Switch
MCB	Miniature Circuit Breaker
MIS	Maintenance Isolation Switch
MOB	Module Output Breaker
REPO	Remote Emergency Power-off
RIB	Rectifier Input Breaker
SCR	Silicon-controlled Rectifier
STS	Static Switch
UPM	Uninterruptible Power Module
UPS	Uninterruptible Power Supply
VMMS	Variable Module Management System

2 Safety instructions



DANGER

Important safety instructions!
Keep these instructions!

This document provides important instructions you should obey during the installation, operation and maintenance of the UPS and the batteries. Read all of the instructions before operating the equipment. Keep this manual for future reference. These instructions are also available for download at www.eaton.eu/93pm.



DANGER

Operations inside the UPS must be done by an authorized Eaton Customer Service Engineer or by other qualified service personnel authorized by Eaton. There are no user-serviceable parts in the UPS.

The UPS operates with mains, battery or bypass power. It contains components that carry high currents and voltage. A correctly installed UPS is earthed and IP20 rated against electric shock and unwanted objects. The UPS is a sophisticated power system and only qualified personnel are allowed to install and service it.



DANGER

This UPS carries lethal voltages. All repairs and service must be done by authorized personnel only. There are no user-serviceable parts inside the UPS.



WARNING

The UPS is powered by its own energy source (batteries). The output terminals may be energized even when the UPS is disconnected from an AC source. To reduce the risk of fire or electric shock, install this UPS in a temperature and humidity controlled, indoor environment that is free of conductive contaminants.

The ambient temperature limit must not be exceeded. Do not operate the UPS near water or excessive humidity. The system is not intended for outdoor use.

Before you start any installation or service work, make sure that all AC and DC power sources are disconnected. Power may come from multiple sources. Also, ensure system grounding / PE continuity.

In a parallel system, the output terminals may be energized even when the UPS is turned off.

WARNING

Batteries present a risk of electrical shock or burn from high short-circuit current. Obey the precautions.

Electric energy hazard. Do not attempt to alter any battery wiring or connectors. Attempting to alter wiring can cause injury.

Do not open or mutilate batteries. Released electrolyte may be toxic and is harmful to the skin and eyes.

Batteries may contain HIGH VOLTAGES, and CORROSIVE, TOXIC and EXPLOSIVE substances. Because of the battery string the output receptacles can carry high voltage even when the AC supply is not connected to the UPS. Read the shutdown instructions carefully.

IMPORTANT: The battery can consist of multiple parallel strings. Make sure that you disconnect all strings before installation.

CAUTION

Only qualified service personnel knowledgeable of batteries and the required precautions can do the installation or service work on batteries. Keep unauthorized personnel away from the batteries. Before you install or replace batteries, consider all the warnings, cautions, and notes concerning appropriate handling. Do not disconnect the batteries when the UPS is in the Battery mode.

Make sure that your replacement batteries are of the same number and type as the battery that was originally installed in the UPS.

Before you connect or disconnect battery terminals, disconnect the charging source by opening the corresponding battery circuit breaker.

Make sure that the battery is not grounded. If it is, remove the source of the ground. Contacting any part of a grounded battery can cause a risk of electric shock. If you disconnect the grounding connection before you work on the batteries, the risk of an electric shock is less likely.

Discard batteries according to your local disposal requirements. Do not discard batteries in a fire. When exposed to flame, batteries may explode.

To ensure correct cooling airflow and to protect personnel from dangerous voltages inside the unit, keep the UPS door closed and the front panels installed.

Do not install or operate the UPS system close to gas or electric heat sources. Keep the operating environment within the parameters stated in this document.

**CAUTION**

Keep the surroundings of the UPS uncluttered, clean, and free from excess moisture.

Obey all DANGER, CAUTION, and WARNING notices on the inside and outside of the equipment.

2.1 Audience

The intended audience of this document are as follows:

- People who plan and perform the installation of the UPS
- People who use the UPS

This document provides guidelines for how to check the UPS delivery and how install and operate the UPS.

The reader is expected to know the fundamentals of electricity, wiring, electrical components and electrical schematic symbols. This document is written for a global reader.

CAUTION

Read this document before you start to operate or perform work on the UPS.

2.2 CE marking

The product has a CE marking in compliance with the following European directives:

- LV Directive (Safety) 2014/35/EU
- EMC Directive 2014/30/EU

Declarations of conformity with UPS harmonized standards and directives EN 62040-1 (Safety) and EN 62040-2 (EMC) are available at www.eaton.eu or by contacting your nearest Eaton office or authorized partner.

2.3 User precautions

The only permitted user operations.

- Startup and shutdown of the UPS, excluding the commissioning startup
- Use of the LCD control panel and the Maintenance Bypass Switch (MBS)
- Use of optional connectivity modules and their software

Obey the precautions and do only the described operations. Do not deviate from the instructions. It can be dangerous to you or cause accidental load loss.

DANGER

Do not open any other screws in the unit than those holding the cover plates of the MiniSlots and the MBS locking plate. Failure to recognize the electrical hazards can prove fatal.

CAUTION

This is a product for commercial and industrial application in the second environment. Installation restrictions or additional measures could be needed to prevent disturbances.

2.4 Environment

The UPS must be installed according to the recommendations in this document. Never install the UPS in an airtight room, in the presence of flammable gases, or in an environment exceeding the specifications.

Excessive amount of dust in the operating environment of the UPS may cause damage or lead to malfunction. Always protect the UPS from the outside weather and sunshine.



WARNING

During charge, float charge, heavy discharge, and overcharge, hydrogen and oxygen gases are emitted from lead-acid and NiCd batteries into the surrounding atmosphere. Explosive gas mixture may be created if the hydrogen concentration exceeds 4% by volume in air. Ensure the necessary air flow rate for the ventilation of the UPS location.

2.5 Symbols on the UPS and accessories

The following are examples of symbols used on the UPS or its accessories. The symbols are used to alert you of important information.

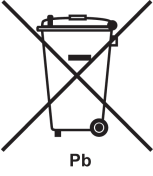
	<p>RISK OF ELECTRIC SHOCK</p> <p>Indicates that a risk of electric shock is present and the associated warning should be observed.</p>
	<p>CAUTION: REFER TO OPERATOR'S MANUAL</p> <p>Refer to your operator's manual for additional information, such as important operating and maintenance instructions.</p>

 <p>Pb</p>	<p>This symbol indicates that you may not discard the UPS or the UPS batteries in the trash. This product involves sealed, lead-acid batteries and they must be disposed of properly. For more information, contact your local recycling / reuse or hazardous waste center.</p>
	<p>This symbol indicates that you may not discard waste electrical or electronic equipment (WEEE) in the trash. For proper disposal, contact your local recycling / reuse or hazardous waste center.</p>

2.6 For more information

Address any inquiries about the UPS and the battery cabinet to the local office or an agent authorized by the manufacturer. Quote the type code and the serial number of the equipment.

Contact your local service representative if you need help with any of the following.

- scheduling initial startup
- regional locations and telephone numbers
- a question about any of the information in this manual
- a question that this manual does not answer



Note: For more information about the installation space, safe operation and working, see IEC 62485-2: Safety requirements for secondary batteries and battery installations.

3 Introduction to Eaton UPS

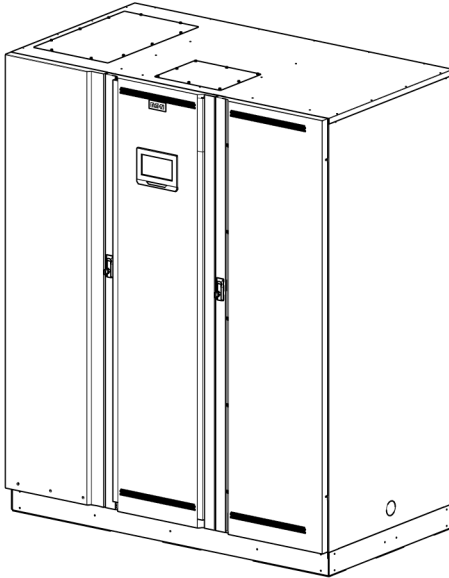

Figure 1. Eaton 93PM UPS

The Eaton® 93PM uninterruptible power supply (UPS) is a true online, continuous-duty, transformerless, double-conversion, solid-state, three-phase system that supplies conditioned and uninterruptible AC power to critical load and protects it from power failures.

The UPS is used to prevent loss of valuable electronic information, minimize equipment downtime, and minimize the adverse effect on production equipment due to unexpected power problems.

The Eaton UPS continually monitors incoming electrical power and removes the surges, spikes, sags, and other irregularities that are inherent in commercial utility power. Working with a building's electrical system, the UPS system supplies clean, consistent power that sensitive electronic equipment require for reliable operation. During brownouts, blackouts, and other power interruptions, batteries provide emergency power to safeguard operation.

The UPS system is housed in a single, free-standing cabinet with safety shields behind the door for protection against hazardous voltage. Each UPS cabinet has a centralized system static bypass. The available static bypass ratings are 400 kVA and 500 kVA. The static bypass size is chosen according to UPS system power.

Eaton 93PM output power ratings are based on 50 kVA and 62,5 kVA rated uninterruptible power modules (UPMs). A single UPS cabinet can house from two to eight UPMs to get ratings of 100 to 400 kVA with 50 kVA module, and 100 to 500 kVA with 62,5 kVA module.

Ratings with 50 kVA module	Ratings with 62,5 kVA module
100 kVA (pf 1.0)	100 kVA (pf 0.95)
150 kVA (pf 1.0)	150 kVA (pf 0.95)
200 kVA (pf 1.0)	200 kVA (pf 0.95)
250 kVA (pf 1.0)	250 kVA (pf 0.9)
300 kVA (pf 1.0)	300 kVA (pf 0.9)
350 kVA (pf 1.0)	350 kVA (pf 0.95)
400 kVA (pf 1.0)	400 kVA (pf 0.95)
	450 kVA (pf 0.95)
	500 kVA (pf 0.9)

See Section 3.7 for a full list of available configurations.

A UPM includes a rectifier, inverter, battery converter, and independent controls. Each UPM is able to operate independently from the other power modules.



Note: Startup and operational checks must be performed by an authorized Eaton Customer Service Engineer or by other qualified service personnel authorized by Eaton, or the terms specified in the Warranty (see Chapter 10) become void. This service is offered as part of the sales contract for the UPS. Contact service in advance (usually a two-week notice is required) to reserve a preferred startup date.

3.1 Looking inside the UPS system

The system level static bypass in the Eaton 93PM UPS cabinet determines the attainable output power of the UPS. The static bypass line consists of static switch, a back feed protection isolation device and fuses designed to protect the static switch. The back feed protection and bypass fuses are located in series with the static switch. In addition, there is a system level control unit that constantly monitors the power delivered through the bypass line or to the input of the UPS. Transfers to static bypass are seamless and performed automatically by the system as needed, for example, in case of an extended system overload.

Each UPM includes a rectifier, battery converter, inverter and independent controls. Each UPM is able to operate and share the load independently, despite the status of the other UPMs.

If utility power is interrupted or falls outside the parameters specified in Chapter 9, the UPS uses a backup battery supply to maintain power to the critical load

for a specified period of time or until the utility power returns. For extended power outages, the UPS allows you to either transfer to an alternative power system (such as a generator) or shut down your critical load in an orderly manner.

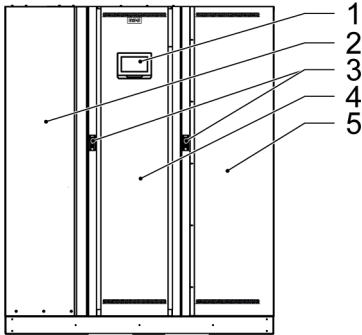

Figure 2. Main parts, outside

- | | |
|------------------------|--------------------------|
| 1 Control panel | 4 Middle door |
| 2 Left panel | 5 Right side door |
| 3 Door latch | |

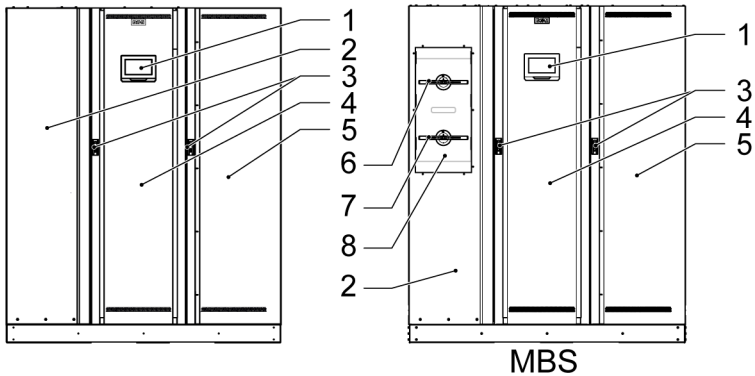

Figure 3. Main parts with MBS, outside

- | | |
|------------------------|--------------------------|
| 1 Control panel | 5 Right side door |
| 2 Left panel | 6 MBP |
| 3 Door latch | 7 MIS |
| 4 Middle door | 8 Cover plate |

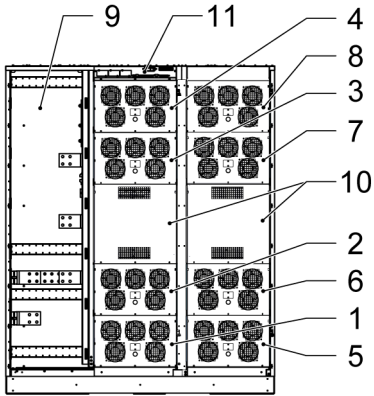

Figure 4. Main parts, inside

- | | | | |
|----------|--------------|-----------|--------------------------------|
| 1 | <i>UPM 1</i> | 7 | <i>UPM 7</i> |
| 2 | <i>UPM 2</i> | 8 | <i>UPM 8</i> |
| 3 | <i>UPM 3</i> | 9 | <i>Connector area</i> |
| 4 | <i>UPM 4</i> | 10 | <i>Static switch</i> |
| 5 | <i>UPM 5</i> | 11 | <i>Communication interface</i> |
| 6 | <i>UPM 6</i> | | |

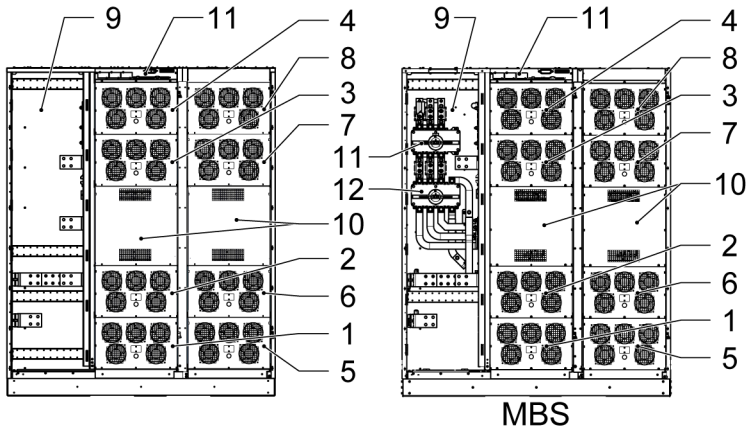

Figure 5. Main parts with MBS, inside

- | | | | |
|---|-------|----|----------------|
| 1 | UPM 1 | 7 | UPM 7 |
| 2 | UPM 2 | 8 | UPM 8 |
| 3 | UPM 3 | 9 | Connector area |
| 4 | UPM 4 | 10 | Static switch |
| 5 | UPM 5 | 11 | MBS |
| 6 | UPM 6 | 12 | MIS |

3.2 UPS operating modes

The UPS operating modes are as follows.

Operating mode	Description
Normal operating modes:	
- Double conversion mode	Critical load is supplied by the inverter, which derives its power from rectified utility AC power. In this mode, the battery charger also provides charging current for the battery, if needed.

Operating mode	Description
- Variable Module Management System (VMMS) mode	Critical load is supplied by the inverter. The inverter derives its power from rectified utility AC power, identically to double conversion mode. In the VMMS mode, the 93PM UPS system is able to optimise the load level per power module: the operating efficiency is significantly improved when operating load is below 50% of UPS capacity. The UPS system will automatically place the redundant power modules to suspended mode. In case of any anomalies in utility or a sudden load increase, the suspended power modules are able to transfer to online mode with less than 2 ms transition time.
- Energy Saver System (ESS) mode	Critical load is supported securely by utility power through the static bypass switch with double conversion available on-demand with typically less than a 2 ms transition time, should any abnormal condition be detected in the utility. When operating in the ESS mode, the load is protected with inherent surge suppression. Operating the UPS in the ESS mode increases system efficiency up to 99%, allowing significant savings in energy losses without compromising system reliability
Stored energy mode	Energy is drawn from a DC backup power source and converted to AC power by the UPS inverter. Most commonly VRLA batteries are introduced to the system for this purpose, and the mode of operation is called the battery mode
Bypass mode	Critical load is supported directly by utility power through the UPS static switch.

3.2.1 Normal operating modes

During normal UPS operation, power for the system is derived from a utility input source. **Unit Online** is displayed on the front panel, indicating that the incoming power is within voltage and frequency acceptance windows.

3.2.1.1 Double conversion mode

Figure 6 shows the path of electrical power through the UPS system when the UPS is operating in the double conversion mode.

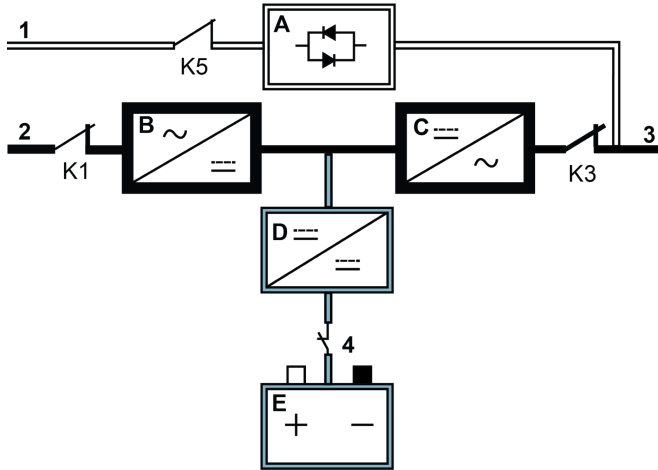

Figure 6. Path of current through the UPS in the double conversion mode

A	Static switch	1	Bypass input		Main power flow
B	Rectifier	2	Rectifier input		Energized
C	Inverter	3	Output		De-energized
D	Battery converter	4	Battery breaker		Trickle current
E	Battery		Closed		Open

Three-phase AC input power is converted to DC using a multilevel converter with IGBT devices to produce a regulated DC voltage to the inverter. The UPS status indicated on the display is **Unit Online** and the UPM status is **Active**.

The battery converter derives its input from the regulated DC output of the rectifier and provides regulated charge current to the battery. The battery is always connected to the UPS and ready to support the inverter should the utility input become unavailable.

The inverter produces a three-phase AC output to the critical load. The inverter uses multilevel converter technology with IGBT devices and pulse-width modulation (PWM) to produce a regulated and filtered AC output.

If the utility AC power is interrupted or is out of specification, the UPS automatically switches to the battery mode to support the critical load without interruption. When utility power returns, the UPS returns automatically to the double conversion mode.

If the UPS becomes overloaded or unavailable, the UPS seamlessly switches to the bypass mode and continues supplying the load through the static bypass. The UPS automatically returns to the double conversion mode when the abnormal condition, such as an extended time overload, is cleared and the system operation is restored within the specified limits.

If a UPM within the UPS suffers an internal failure, the remaining UPMs continue to support the load in the double conversion mode. The UPS is automatically internally redundant when the UPS is not operating at full load. However, if internal redundancy between the UPMs is not possible due to high load, the UPS switches automatically to the bypass mode and remains in that mode until the failure is corrected and the UPS is back in operation.

In an external parallel redundant system, each UPS can be isolated from the system for service while the remaining UPSs support the load in the double conversion mode.

3.2.1.2 Variable Module Management System mode

When Variable Module Management System (VMMS) mode is enabled, the load is powered by UPMs in double conversion mode (see Figure 6). The UPS status indicated on the display is **Unit Online VMMS** and the UPM status is **Active**.

UPS efficiency varies according to the load level at which the UPS operates. VMMS technology enables achieving optimised system efficiency by automatically optimising the UPM load level. As an example, when the load is very low, a minimum of one UPM is online. This enhances the UPS system efficiency by several percentage points.

The remaining UPMs are ready to switch to double conversion mode instantaneously, if the load increases. The load will remain protected by double conversion UPS the entire time, even during and after a load step.

It is possible to configure VMMS mode to include power module redundancy at all times, so that a number of additional redundant UPMs are always online.

When the UPMs are in ready state, the IGBT converters are constantly powered, since the rectifier input and inverter output contactors are closed. The DC link is also powered. Only the IGBT gate signals are suspended. The only step needed to come out of ready state is to gate the IGBT switches. Since DC voltage is constantly present, the inverter is able to start instantaneously: the 2 ms transfer to double conversion is practically seamless.

3.2.1.3 Energy Saver System mode

Figure 7 shows the path of electrical power through the UPS system when the UPS is operating in the Energy Saver System (ESS) mode.

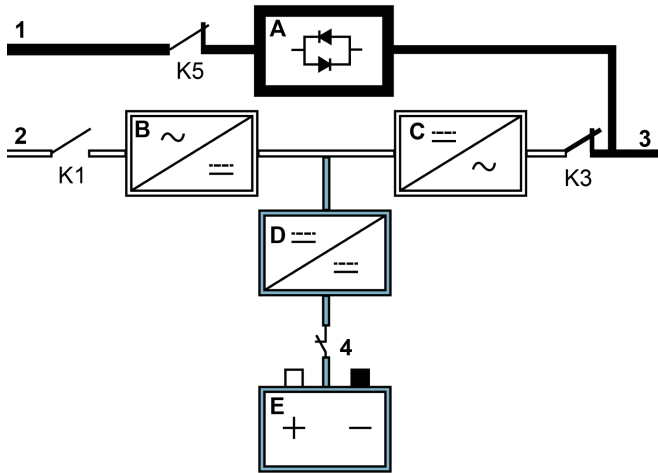







Figure 7. Path of current through the UPS in the Energy saver System mode

A	Static switch	1	Bypass input		Main power flow
B	Rectifier	2	Rectifier input		Energized
C	Inverter	3	Output		De-energized
D	Battery converter	4	Battery breaker		Trickle current
E	Battery		Closed		Open
			Open		

In the ESS mode, the UPS safely provides mains current directly to the load when the input is within the acceptable limits by its voltage and frequency. The UPS status indicated on the display is **Unit Online ESS**, and the UPM status is **Active**. Surge protection and some filtering is also provided, making sure that clean power is delivered to the load equipment. In case any disturbances are detected in the incoming power, the UPS switches to the double conversion mode and continues to supply the critical load through its inverter. In case of a complete utility outage or if the input power is outside the tolerances of the system, the UPS transfers to the battery mode and continues to supply conditioned, clean power to the critical load.

When operating in the ESS mode, the UPS's superior detection and control algorithms continuously monitor the incoming power quality and allow fast engagement of the power converters. Typical transition time to the double conversion mode is less than 2 milliseconds, which is practically seamless.

When the power conditions are within acceptable limits, the UPS operates as a high efficiency, energy-saving system, providing surge protection for IT equipment and making sure that clean power is delivered to the facility. The energy saver system increases system efficiency up to 99% when supplying 20–100% of nominal load, reducing energy losses by up to 80%.

3.2.2 Stored energy and battery mode

When running normally in the double conversion or ESS mode, the UPS automatically transfers to supply the load from batteries or some other stored energy source if a utility power outage occurs, or if the utility power does not conform to the specified parameters. The UPS status indicated on the display is **On Battery**, and the UPM status is **Active**. In the battery mode, the battery provides emergency DC power, which is converted to regulated output power by the inverter.

Figure 8 shows the path of electrical power through the UPS system when operating in the battery mode.

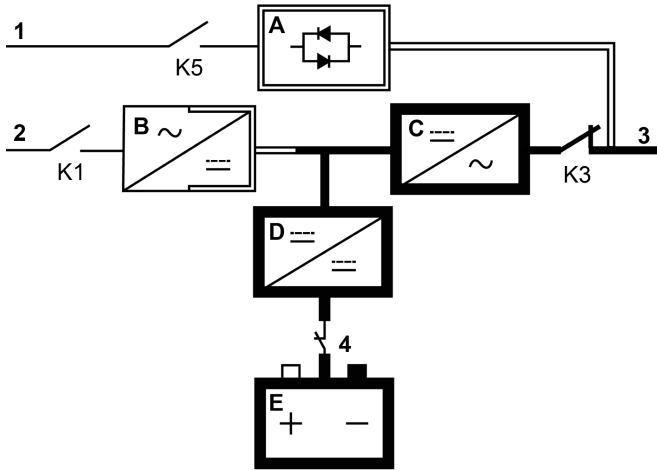

Figure 8. Path of current through the UPS in the battery mode

A	Static switch	1	Bypass input		Main power flow
B	Rectifier	2	Rectifier input		Energized
C	Inverter	3	Output		De-energized
D	Battery converter	4	Battery breaker		Trickle current
E	Battery		Closed		Open

During a utility power failure, the rectifier no longer has an AC utility source from which to supply the DC output current required to support the inverter. The input relay K1 opens and the UPS output is powered from the batteries through the inverter. As the inverter operates uninterrupted through the transition, the load remains supported continuously without disturbance. If the UPS static bypass is supplied from the same source as the UPS rectifier, the backfeed protection contactor K5 also opens. The opening of K1 and K5 prevent system voltages from bleeding backwards and re-entering the input source through the static switch or rectifier.

If the input power fails to return or is not within the acceptance windows required for normal operation, the battery continues discharging until a DC voltage level is reached where the inverter output can no longer support the connected loads. When this event occurs, the UPS issues a set of audible and visual alarms indicating that the batteries have a minimal capacity left and a system shutdown is imminent. Unless utility power is restored, the output can be supported for a

maximum of 2 minutes before the output of the system shuts down. If the bypass source is available, the UPS transfers to the bypass mode instead of shutting down.

If the input power becomes available again at any time during the battery discharge, K1 and K5 close and the UPS returns to normal operation. The UPS also starts to recharge the batteries to restore the capacity.

3.2.3 Bypass mode



CAUTION

The critical load is not protected while the UPS is in bypass mode.

The UPS automatically switches to the bypass mode if it detects an overload, load fault, or internal failure. The bypass source supplies the commercial AC power to the load directly. The UPS can also be commanded to transfer to the bypass mode manually through the display. The UPS status indicated on the display is **On Bypass**.

The UPS returns from the bypass mode back to online mode, if the condition (for example overload) that caused the transfer is cleared. If there is a condition that does not clear by itself (for example UPS internal failure), the UPS remains on bypass operation.

Figure 9 shows the path of electrical power through the UPS system when operating in the bypass mode.

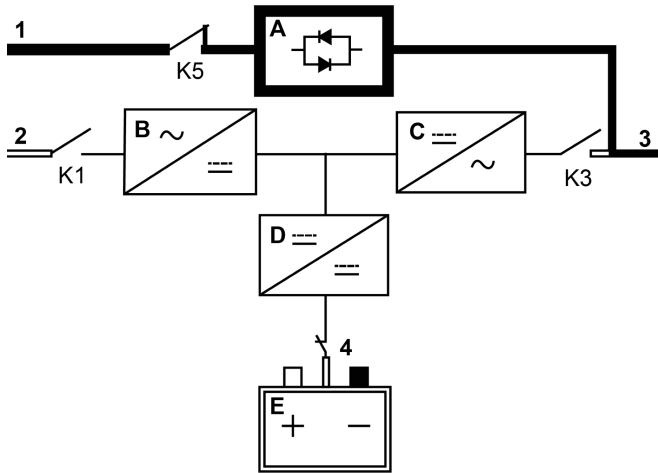







Figure 9. Path of current through the UPS in the bypass mode

A	Static switch	1	Bypass input		Main power flow
B	Rectifier	2	Rectifier input		Energized
C	Inverter	3	Output		De-energized
D	Battery converter	4	Battery breaker		Trickle current
E	Battery		Closed		Open

In the bypass mode, the output of the system is provided with three-phase AC power directly from the system input. While in this mode, the output of the system is not protected from voltage or frequency fluctuations or power outages from the source. Some power line filtering and transient protection is provided to the load, but no active power conditioning or battery support is available to the output of the system in the bypass mode.

The static bypass consists of a solid-state, silicon-controlled rectifier (SCR) static switch (STSW) and a backfeed protection isolation device K5. The static switch is rated as a continuous-duty device that is used anytime the inverter is unable to support the applied load. The static switch is wired in series with the backfeed protection. As the static switch is an electronically-controlled device, it can be turned on immediately to pick up the load from the inverter without interruption. The backfeed protection is normally always closed, ready to support the static switch unless the bypass input source becomes unavailable.

3.3 UPS features

The Eaton UPS has many features that provide cost-effective and consistently reliable power protection. The feature descriptions provide a brief overview of the UPS standard features.

3.3.1 Advanced Battery Management

The Advanced Battery Management technology uses sophisticated sensing circuitry and a three-stage charging technique that extends the useful service life of UPS batteries while optimizing the battery recharge time. ABM also protects batteries from damage caused by high current charging and inverter ripple currents. Charging at high currents can overheat and damage batteries.

In the *charge mode*, the batteries are recharged. Charging lasts only as long as it takes to bring the battery system up to a predetermined float level. Once this level is reached, the UPS battery charger enters the *float stage* and the charger operates in the constant voltage mode.

The *rest mode* begins at the end of the charge mode; that is, after 48 hours of float charging (user-adjustable). In the rest mode, the battery charger is completely turned off. The battery system receives no charge current during this rest period of approximately 28 days (user-adjustable). During the rest mode, the open circuit battery voltage is monitored constantly, and battery charging is resumed when necessary.

3.3.2 Powerware Hot Sync

The Eaton Powerware Hot Sync technology is an algorithm that eliminates the single point of failure in a parallel system and therefore enhances system reliability. The Hot Sync technology is incorporated in all Eaton 93PM UPSs, and it is utilized in both multi-module internal parallel and external parallel systems.

The Hot Sync technology enables all UPMs to operate independently in a parallel system, even without inter-module communications. The power modules utilizing the Hot Sync technology are completely autonomous; each module monitors its own output independently to remain in complete synchronization with the other modules. The UPM power modules share the load perfectly even in changing capacity or load conditions.

The Powerware Hot Sync technology combines digital signal processing and an advanced control algorithm to provide automatic load sharing and selective tripping in a parallel UPS system. The load share control algorithms maintain synchronization and load balance by constantly making minute adjustments to variations in the output power requirements. The modules conform to demand and are not in conflict with each other for the load. The Powerware Hot Sync systems are capable of paralleling for both redundancy and capacity.

3.3.3 Power Conditioner

The Power Conditioner mode is characterized by the UPS running in the double conversion mode without batteries connected. In the Power Conditioner mode, the UPS provides conditioned output voltage and frequency. The UPS can also support high nonlinear loads without ITHD on the input. The UPS meets the qualifications outlined in this product specification, except for the conditions below.

When in the Power Conditioner mode, the UPS has the following functionality and limitations:

1. The UPS runs in the double conversion mode.
2. Because there is no battery, loss of utility power results in the UPS losing power and shutting down.
3. The UPS sustains up to -50% input voltage tolerance, unless the current limit is reached.
4. If the rectifier is turned off, the UPS attempts a transfer to the bypass mode.
5. The ESS mode is not available.
6. The Power Conditioner mode is available in both 3 and 4 wire configurations.

3.3.4 Frequency Converter

The Frequency Converter mode is characterized by the UPS running without the bypass mode available. The output frequency can be configured to be different from the standard input frequency (e.g. 60 Hz output, 50 Hz input). The UPS can also support high nonlinear loads without iTHD on the input. The UPS meets the qualifications outlined in this product specification, except for the conditions below.

When in the Frequency Converter mode, the UPS has the following functionality and limitations:

1. Operation is the same as when in the double conversion mode with no bypass available.
2. Bypass alarms are suppressed.

3.3.5 Sync Control

The Eaton® Sync Control maintains the critical load outputs of two separate UPS systems in synchronization. Use of the Eaton Fixed Master Sync Control provides uninterrupted transfer of the load from one load bus to another by means of downstream, dual-source, solid-state transfer switches. Without the load sync option, the two system output (critical load) buses can become out of phase with each other. This condition occurs when suitable bypass sources are not available or when the bypass sources feeding each system are not in sync with each other. Examples of this condition are two systems supplied by

separate generator sets, or situation where the bypass sources for the two systems are lost.

3.4 Software and connectivity features

3.4.1 User interface

MiniSlot Communication Bays — there are 3 communication bays for MiniSlot connectivity cards. MiniSlot cards are quickly installed and hot-pluggable. See Chapter 6 for additional information.

3.4.2 Power Management Software

Intelligent Power software products offer tools for monitoring and managing power devices across the network. See Chapter 6 for more information.

3.5 Options and accessories

Contact your Eaton sales representative for more information about the available options and accessories.

3.5.1 Maintenance Bypass Switch

The Maintenance Bypass Switch (MBS) enables power to completely bypass and isolate the UPS so that the UPS can be safely serviced or replaced without interrupting power to critical systems. An internal maintenance bypass switch is provided as factory installed option. The internal MBS includes a Maintenance Bypass Switch (MBP) and a UPS Output Maintenance Isolation Switch (MIS).

Alternatively, the MBS is available in an external enclosure as an accessory item.

3.5.2 Top air exhaust kit

The top air exhaust kit is used to direct the UPS cooling air front-to-top. The kit will eliminate the cooling clearance requirement from the back of the unit, and enable installing the UPS even against a wall, in a corner or back-to-back. The kit increases the depth of the unit by 200 mm.

Refer to Section 4.3 for further information.

3.5.3 Single feed kit

The Eaton 93PM UPS is configured for dual feed by standard, requiring a separate feed for rectifier and static bypass input. Single feed kit is available both as factory installed or on-site installed option.

3.5.4 Field Installed UPM

A Field Installed UPM (F-UPM) can be installed in the cabinet any time in the future when power needs change. This enables the UPS system to grow with the business, thus lowering the initial investment required for the system on day one.

In order to install an F-UPM, the UPS cabinet needs to have upgradeability, which is determined by the power rating of the static bypass.

For a listing of the upgradeable configurations, see Table 2 and Table 3.



CAUTION

Only qualified service personnel can install a F-UPM.



Note: Examine the cable and fuse rating before power upgrading.

3.6 Battery system

The battery system provides short-term emergency backup power to safeguard operation during brownouts, blackouts, and other power interruptions. By default, this UPS is configured to use VRLA batteries. If you need to connect other type of batteries or other energy storage means, consult a certified service technician before you proceed with the installation.

The UPS can be equipped with an external battery system. Eaton offers external battery cabinets to be used together with Eaton 93PM UPS.

For detailed battery specifications, see Section 9.5.

3.6.1 UPS Battery Switchgear

The purpose of the UPS Battery Switchgear is to ease the installation of external battery cabinets or battery racks. The UPS Battery Switchgear offering contains models with one main battery breaker and casing, as well as models that support connecting several battery cabinets or racks in parallel. In the multi-breaker solutions, the main breaker is rated to match the UPS's power and the dedicated battery string breakers can be sized either with or without redundancy.

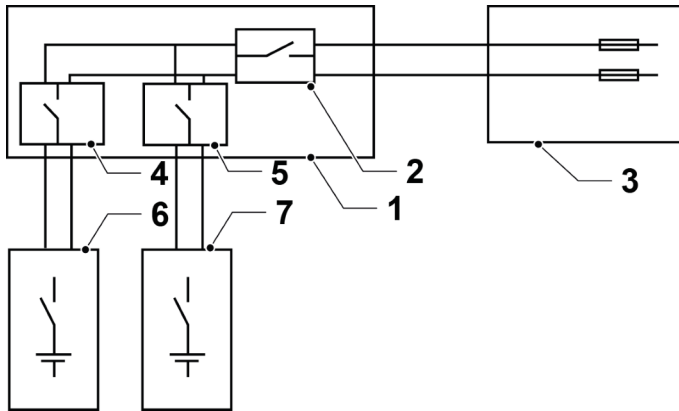

Figure 10. External Battery Switchgear cabling diagram

- | | | | |
|---|-----------------------------|---|--------------------------|
| 1 | External Battery Switchgear | 5 | String breaker <i>n</i> |
| 2 | Breaker | 6 | Battery cabinet 1 |
| 3 | UPS | 7 | Battery cabinet <i>n</i> |
| 4 | String breaker 1 | | |

3.7 Basic system configurations

UPS power rating

The maximum attainable UPS system power rating is determined by the size of the UPS cabinet frame. The number of UPM power modules determines the nominal power rating of the UPS. If upgradeability is required, the system static bypass should be chosen according to the future maximum load rating, and the number of UPMs is chosen according to the capacity requirements on day one.

The following UPS configurations with different static bypass sizes and number of UPMs are possible:

Table 2: UPS configurations, 50 kVA module

Description	System power [kVA]	Power modules	Static switch [kVA]
93PM-100(400)	100	2 x 50 kVA	400
93PM-150(400)	150	3 x 50 kVA	400
93PM-200(400)	200	4 x 50 kVA	400
93PM-250(400)	250	5 x 50 kVA	400
93PM-300(400)	300	6 x 50 kVA	400
93PM-350(400)	350	7 x 50 kVA	400

Description	System power [kVA]	Power modules	Static switch [kVA]
93PM-100(400)	400	8 x 50 kVA	400

Table 3: UPS configurations, 62,5 kVA module

Description	System power [kVA]	Power modules	Static switch [kVA]
93PM-100(500)	100	2 x 62,5 kVA	500
93PM-150(500)	150	3 x 62,5 kVA	500
93PM-200(500)	200	4 x 62,5 kVA	500
93PM-250(500)	250	4 x 62,5 kVA	500
93PM-300(500)	300	5 x 62,5 kVA	500
93PM-350(500)	350	6 x 62,5 kVA	500
93PM-400(500)	400	7 x 62,5 kVA	500
93PM-450(500)	450	8 x 62,5 kVA	500
93PM-500(500)	500	8 x 62,5 kVA	500

A single UPS frame can house maximum eight UPMs, resulting in maximum power rating of 500 kVA. In addition, the UPS frames can be connected in parallel to create even larger systems. A maximum of four UPSs can be connected in parallel.

UPS options and accessories

The following table shows different standard and optional UPS features.

Table 4: Standard and optional UPS features

Feature	Retrofittable	All models
Smart touch screen display for system control and monitoring		Standard
Battery start		Standard
Integrated backfeed protection		Standard
Static bypass protective fuses		Standard
Kick plates		Standard
Sync control interface	No	Option
Top air exhaust kit	No	Option
Parallel cable kit	Yes	Option
Single feed kit	Yes	Option
Internal maintenance bypass switch	No	Option

Additional options and accessories are also available. These include different software and connectivity options and external switchgear and power distribution options.

4 UPS installation plan and unpacking

Use the following basic sequence of steps to install the UPS:

1. Create an installation plan for the UPS system.
2. Prepare your site for the UPS system.
3. Inspect and unpack the UPS cabinet.
4. Unload and install the UPS cabinet and wire the system.
5. Complete the installation checklist provided in Section [4.2](#).
6. Have authorized service personnel perform the preliminary operational checks and startup.



Note: Startup and operational checks must be performed by an authorized Eaton Customer Service Engineer or by other qualified service personnel authorized by Eaton, or the terms specified in the Warranty (see Chapter [10](#)) become void. This service is offered as a part of the sales contract for the UPS. Contact service in advance (usually a two-week notice is required) to reserve a preferred startup date.

4.1 Creating an installation plan

Before you install the UPS system, read and understand how these instructions apply to the system that you are going to install. Use the procedures and illustrations in Section [4.3](#) and Chapter [5](#) to create a logical plan for installing the system.

4.2 Installation checklist

Action	Yes / No
All packing materials and restraints are removed from each cabinet.	
Each cabinet in the UPS system is placed in its installed location.	
A cabinet grounding kit / mounting kit is installed between any cabinets that are bolted together.	
All conduits and cables are properly routed to the UPS and any ancillary cabinets.	
All power cables are properly sized and terminated.	
Neutral conductors are installed and bonded to ground according to the requirements.	
A ground conductor is properly installed.	
Battery cables are terminated and connected to battery connectors.	
Battery Shunt trip and Aux contact signal wiring is connected from the UPS to the battery breaker.	
LAN drops are installed.	
All LAN connections are completed.	
Air conditioning equipment is installed and operating correctly.	
There is adequate workspace around the UPS and other cabinets.	
Adequate lighting is provided around all the UPS equipment.	
A 230 VAC service outlet is located within 7.5 meters of the UPS equipment.	
The Remote Emergency Power-off (REPO) device is mounted in its installed location and its wiring is terminated inside the UPS cabinet.	
If EPO is used in the NC configuration, a jumper is installed on the EPO between pins 1 and 2.	
(OPTIONAL) Alarm relays and signal outputs are wired appropriately.	
(OPTIONAL) A remote battery disconnect control is mounted in its installed location and its wiring is terminated inside the UPS and battery cabinet.	
(OPTIONAL) Accessories are mounted in their installed locations and their wiring is terminated inside the UPS cabinet.	
Start-up and operational checks are performed by an authorized Eaton Customer Service Engineer.	

4.3 Site preparations

For the UPS system to operate at peak efficiency, the installation site must meet the environmental parameters outlined in these instructions. If the UPS needs to be operated at an altitude higher than 1,000 m, contact your service representative for important information about high altitude operation. The

operating environment must meet the height, clearance, and environmental requirements specified.

4.3.1 Environmental and installation considerations

The UPS system can be installed where there is TN, TT, or IT power distribution system.

- Install the system indoors on a level floor suitable for computer or electronic equipment. The floor must be suitable for heavy weight and wheeling.
- Install the system in a temperature and humidity controlled area, where the dew point cannot be reached.
- Install the system in an area that is free of conductive contaminants.
- Install the cabinet either in line-up-and-match or standalone configurations.

If you do not obey these guidelines your warranty can become void.

The UPS equipment operating environment must meet the weight requirements shown in Table 5, and the size requirements shown in Table 6.

Table 5: UPS cabinet maximum weights

UPS model	Shipping weight [kg]	Installed weight [kg]	Floor loading [kg/m ²]
93PM-100(400)	720	680	439
93PM-150(400)	785	745	540
93PM-200(400)	850	810	587
93PM-250(400)	915	875	635
93PM-300(400)	980	940	682
93PM-350(400)	1045	1005	729
93PM-400(400)	1110	1070	776
93PM-100(500)	720	680	439
93PM-150(500)	785	745	540
93PM-200(500)	850	810	587
93PM-250(500)	850	810	587
93PM-300(500)	915	875	635
93PM-350(500)	980	940	682
93PM-400(500)	1045	1005	729
93PM-450(500)	1110	1070	776
93PM-500(500)	1110	1070	776

Table 6: UPS cabinet dimensions

Dimensions (W x D x H) mm	93PM-xxx(400)	93PM-xxx(500)
Shipping dimensions	1800 x 990 x 2120	1800 x 990 x 2120

Dimensions (W x D x H) mm	93PM-xxx(400)	93PM-xxx(500)
Cabinet dimensions	1618 x 920 x 1968	1618 x 920 x 1968

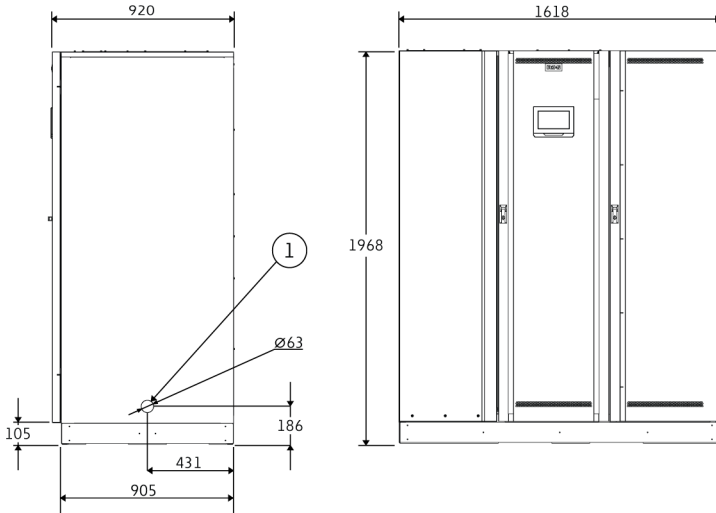

Figure 11. 93PM UPS side dimensions, without top-air exhaust option

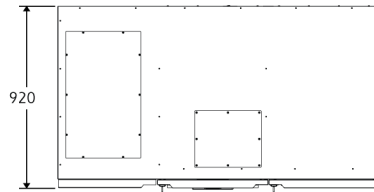

Figure 12. 93PM UPS side dimensions, without top-air exhaust option

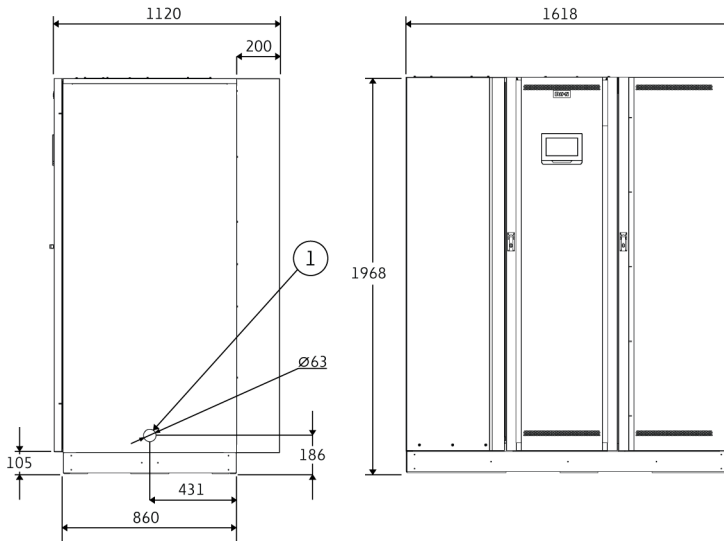

Figure 13. 93PM UPS top dimensions, with top-air exhaust option

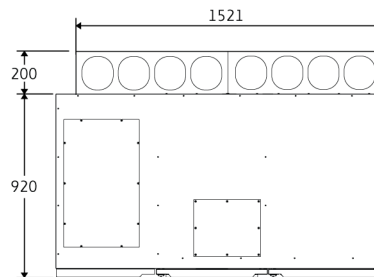

Figure 14. 93PM UPS top dimensions, with top-air exhaust option

The UPS cabinets use forced air cooling to regulate internal component temperature. By standard, air inlets are in the front of the cabinet and outlets are in the back. You must allow clearance in front of and behind each cabinet for proper air circulation.

With the optional top air exhaust kit, it is possible to configure the air outlets in the top rear of the cabinet. With this option, the UPS can be installed against a wall or back-to-back.

The clearances required around the UPS cabinet in both of these situations are shown in Table 7.

Table 7: UPS cabinet clearances

	93PM-xxx(400)	93PM-xxx(500)
From the top of the cabinet	500 mm	500 mm
From the front of the cabinet	900 mm	900 mm
From the back of the cabinet	450 mm*	450 mm*
From the side of the cabinet	0 mm	0 mm

*) 0 mm if top air exhaust kit installed

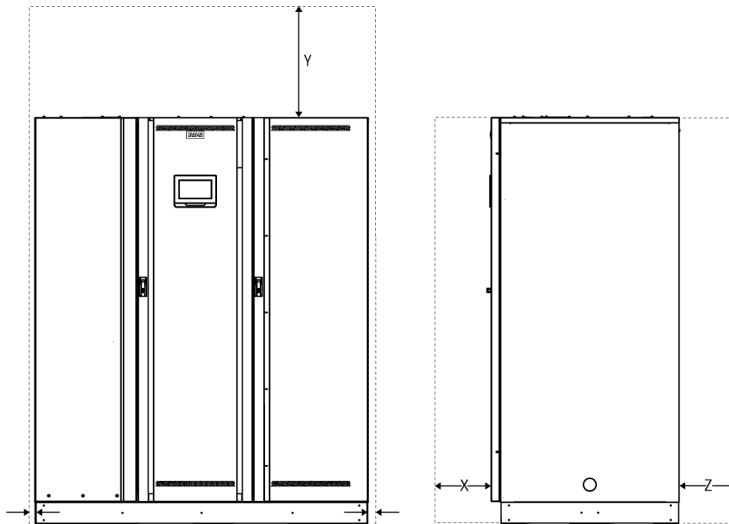

Figure 15. 93PM UPS cabinet clearances

Z = clearance at the back
X = clearance at the front

Y = clearance at the top

The basic environmental requirements for operation of the UPS system.

- Ambient temperature range: from +0...+35 °C
- Ambient temperature range for the 400 kW UPS cabinet: from +0...40 °C
- Recommended operating range for VRLA batteries: +20...25 °C
- Maximum relative humidity: 95%, non-condensing

You must arrange ventilation of the UPS room. Sufficient amount of air cooling is needed to keep the maximum room temperature rise at desired level.

- Temperature rise of max. +5 °C requires the airflow of 600 m³/h per 1 kW of losses
- Temperature rise of max. +10 °C requires the airflow of 300 m³/h per 1 kW of losses

An ambient temperature from +20 to +25 °C is recommended to achieve a long life of the UPS and batteries. The cooling air entering the UPS must not exceed +40 °C. Avoid high ambient temperature, moisture, and humidity.

For ventilation requirements, see 93PM heat rejection in the following table:

Table 8: Air conditioning or ventilation requirements during full load operation

Rating	Heat rejection (BTU/h x 1,000)	Heat rejection [kW]
93PM-100(400)	13	3,8
93PM-150(400)	20	5,8
93PM-200(400)	26	7,7
93PM-250(400)	33	9,6
93PM-300(400)	38	11,2
93PM-350(400)	45	13,1
93PM-400(400)	50,5	14,8
93PM-100(500)	13	3,8
93PM-150(500)	19	5,6
93PM-200(500)	25	7,3
93PM-250(500)	30	8,9
93PM-300(500)	35	10,4
93PM-350(500)	44	12,8
93PM-400(500)	49,5	14,5
93PM-450(500)	56	16,4
93PM-500(500)	58,7	17,2

4.3.2 UPS system power wiring preparations



Note:

If you install an unit with internal maintenance bypass (MBS):

- The static bypass input (X2) and rectifier input (X1) must have external isolators to isolate these feeds from the MBS input (X8) during service operations.
- Do not connect the MBS input (X8) to a different source than the static bypass input (X2).

**Note:**

If you install an external maintenance bypass (MBS):

- The UPS static bypass input (X2) and UPS rectifier input (X1) must have external isolators to isolate these feeds from the external MBS input during service operations.
- Do not connect the external MBS input to a different source than the UPS static bypass input (X2).

When you plan and do the installation, read and understand these notes:

- Refer to national and local electrical codes for acceptable external wiring practices.
- To allow for future kVA upgrades (software and/or hardware), consider using conductors sized for full bypass rating of the UPS.
- Material and labor for external wiring requirements must be provided by designated personnel.
- For external wiring, use copper cable rated for 70 °C at minimum. See the appropriate information in Tables 9 and 10. Cable sizes are based on using the specified breakers.
- If cables are run in an ambient temperature greater than 30 °C, higher temperature cable and/or larger size cable could be necessary.
- The bypass feed into this equipment uses three phases or three phases and neutral. The rectifier feed into this equipment uses three phases or three phases and neutral. The phases must be symmetrical about ground (from a Wye source) for proper equipment operation.
- If the load requires a neutral, a bypass source neutral must be provided. If the load does not require a neutral and there is no neutral conductor connected at the bypass input, a neutral must be installed to source star point.
- Include a readily accessible disconnect device in all fixed input wiring.

WARNING

Do not disconnect the bypass neutral without disconnecting the bypass phases at the same time.

Table 9: Minimum recommended multi-core cable and fuse sizes for rectifier input, bypass input and UPS output connections

UPS model	Phase cables [mm ²]	Rectifier, bypass and MBS input fuse [A]	PE cable [mm ²]
93PM-100(400)	95 mm ²	200 A	50 mm ²
93PM-150(400)	185 mm ²	315 A	95 mm ²
93PM-200(400)	240 mm ²	400 A	120 mm ²

UPS model	Phase cables [mm ²]	Rectifier, by-pass and MBS input fuse [A]	PE cable [mm ²]
93PM-250(400)	2 x 120 mm ² per phase	500 A	120 mm ²
93PM-300(400)	2 x 185 mm ² per phase	630 A	185 mm ²
93PM-350(400)	2 x 240 mm ² per phase	700 A	240 mm ²
93PM-400(400)	2 x 240 mm ² per phase	800 A	240 mm ²
93PM-100(500)	95 mm ²	200 A	50 mm ²
93PM-150(500)	185 mm ²	315 A	95 mm ²
93PM-200(500)	240 mm ²	400 A	120 mm ²
93PM-250(500)	2 x 120 mm ² per phase	500 A	120 mm ²
93PM-300(500)	2 x 120 mm ² per phase	500 A	120 mm ²
93PM-350(500)	2 x 185 mm ² per phase	630 A	185 mm ²
93PM-400(500)	2 x 240 mm ² per phase	800 A	240 mm ²
93PM-450(500)	2 x 240 mm ² per phase	800 A	240 mm ²
93PM-500(500)	2 x 240 mm ² per phase	800 A	240 mm ²

CAUTION



Make sure that prospective short-circuit current resulting at the input terminals of the UPS is equal or less than conditional short-circuit current declared on the type plate of the UPS.

Table 10: Minimum recommended multi-core cable and fuse sizes for battery connection

UPS model	Battery cable, pos. & neg. line [mm ²]	Battery fuse [A]
93PM-100(400)	185 mm ² per pole	315 A
93PM-150(400)	240 mm ² per pole	400 A
93PM-200(400)	2 x 185 mm ² per pole	630 A
93PM-250(400)	2 x 240 mm ² per pole	700 A
93PM-300(400)	2 x 240 mm ² per pole	800 A
93PM-350(400)	4 x 120 mm ² per pole	1000 A
93PM-400(400)	4 x 185 mm ² per pole	1250 A
93PM-100(500)	120 mm ² per pole	250 A
93PM-150(500)	240 mm ² per pole	400 A
93PM-200(500)	2 x 120 mm ² per pole	500 A
93PM-250(500)	2 x 185 mm ² per pole	630 A
93PM-300(500)	2 x 240 mm ² per pole	800 A
93PM-350(500)	4 x 120 mm ² per pole	1000 A
93PM-400(500)	4 x 120 mm ² per pole	1000 A
93PM-450(500)	4 x 185 mm ² per pole	1250 A

UPS model	Battery cable, pos. & neg. line [mm ²]	Battery fuse [A]
93PM-500(500)	4 x 185 mm ² per pole	1250 A



Note: UPS power upgrading is possible only if the sizing of the external cables is sufficient. Alternatively, the external cabling must be upgraded as well. Fuses are of the type gG.

Cable sizing is based on the standard IEC 60364-5-52 table B.52.2 and IEC 60364-5-54 table B.54.2. Sizing is for 70 °C rated copper cables.

Table 11: Rated and maximum currents for rated power and voltage, rectifier input and UPS output / bypass

Rated power [kW]	Rated voltage [V]	Rectifier input		UPS output / bypass Rated current [A]
		Rated current [A]	Maximum current [A]	
93PM-100(400)	380	184	190	152
	400	175	190	144
	415	168	190	139
93PM-150(400)	380	276	285	228
	400	262	285	217
	415	253	285	209
93PM-200(400)	380	368	380	304
	400	350	380	289
	415	337	380	278
93PM-250(400)	380	46	475	380
	400	437	475	361
	415	421	475	348
93PM-300(400)	380	552	570	456
	400	524	570	433
	415	505	570	417
93PM-350(400)	380	644	665	532
	400	612	665	505
	415	590	665	487

Rated power [kW]	Rated voltage [V]	Rectifier input		UPS output / bypass Rated current [A]
		Rated current [A]	Maximum current [A]	
93PM-400(400)	380	736	760	608
	400	699	760	577
	415	674	760	556

Table 12: Rated and maximum currents for rated power and voltage, rectifier input and UPS output / bypass

Rated power [kW]	Rated voltage [V]	Rectifier input		UPS output / bypass Rated current [A]
		Rated current [A]	Maximum current [A]	
93PM-100(500)	380	169	184	152
	400	161	184	144
	415	155	184	139
93PM-150(500)	380	253	276	228
	400	241	276	217
	415	232	276	209
93PM-200(500)	380	339	368	304
	400	322	368	289
	415	310	368	278
93PM-250(500)	380	386	420	380
	400	350	420	361
	415	337	420	348
93PM-300(500)	380	465	504	456
	400	441	504	433
	415	425	504	417
93PM-350(500)	380	583	643	532
	400	554	643	505
	415	534	634	487
93PM-400(500)	380	669	700	608
	400	636	700	577
	415	613	700	556
93PM-450(500)	380	753	800	684
	400	715	800	650
	415	689	800	626

Rated power [kW]	Rated voltage [V]	Rectifier input		UPS output / bypass Rated current [A]
		Rated current [A]	Maximum current [A]	
93PM-500(500)	380	772	800	760
	400	734	800	722
	415	707	800	696

**Note:**

Maximum rectifier current calculated at the -15% voltage tolerance and 102% continuous overload.

Table 13: Rated and maximum currents for rated power and voltage, battery

Rated power [kW]	Battery	
	Rated current [A]	Maximum current* [A]
93PM-100(400)	230	265
93PM-150(400)	340	398
93PM-200(400)	450	531
93PM-250(400)	560	664
93PM-300(400)	670	769
93PM-350(400)	780	929
93PM-400(400)	890	1062
93PM-100(500)	220	252
93PM-150(500)	320	377
93PM-200(500)	430	504
93PM-250(500)	500	597
93PM-300(500)	600	717
93PM-350(500)	740	881
93PM-400(500)	850	1009
93PM-450(500)	950	1133
93PM-500(500)	1000	1194

*) Maximum battery current calculated at rated load in the end of discharge of VRLA battery (1.67 V per cell).

Table 14: UPS power cable terminations

Terminal function	Terminal	Function
AC input to UPS rectifier	X1	L1, L2, L3, N
AC input to bypass	X2	L1, L2, L3, N

Terminal function	Terminal	Function
UPS output	X3	L1, L2, L3, N
DC input from external battery to UPS	X4	battery +, battery -
MBS input	X8	L1, L2, L3, N
Protective Earth	PE	PE



Note: External overcurrent protection is not provided by this product, but is required by codes. Refer to Tables 9 and 10 for wiring requirements. If an output lockable disconnect is required, it is to be supplied by the user.

Table 15: UPS power cable terminal bolt torques

Function	Tightening torque [Nm]	Bolt size
Phases	80 Nm	M12
Neutral and PE	47 Nm	M10

CAUTION



To reduce the risk of a fire, connect only to a circuit that is provided with maximum input circuit breaker current ratings from Tables 11, 12 and 13 in accordance with the national and local installation rules.

The line-to-line unbalanced output capability of the UPS is limited only by the full load per phase current values for AC output to critical load shown in Tables 11, 12 and 13. The recommended line-to-line load unbalance is 50% or less.

Source protection for the AC input to bypass must suit the characteristics of the load and take into account effects such as inrush or starting current.

Bypass and output overcurrent protection and bypass and output disconnect switches must be provided by the user.

4.4 Unpack and unload the UPS

Before you start to unpack and unload the UPS, check the TipNTell indicator on the package surface and the DropNTell indicator on the UPS after unpacking (see step 2 below). If the equipment has been correctly transported in the upright position, the indicator should be intact. If the indicator arrow has turned all blue, contact the appropriate parties to report inappropriate transportation.

WARNING



The UPS cabinet is heavy. If the unpacking instructions are not closely followed, the cabinet may tip over and cause serious injury.

Do not tilt the UPS cabinet more than 10 degrees from the vertical or the cabinet may tip over.

For transportation purposes, the UPS cabinet is bolted onto a wooden pallet. To remove the pallet, do this procedure.

1. Before you unload the cabinet from the pallet, use a forklift or other material handling equipment to move the cabinet to the installation area. Insert the forks of the forklift between the skids on the bottom of the unit.

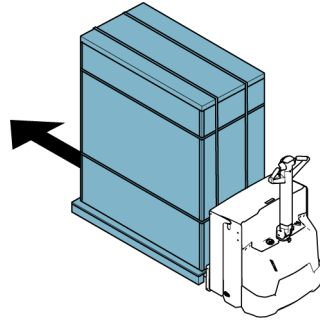

2. Make a visual inspection and make sure that there are no signs of shipping damages. Examine the indicators. See the instructions next to the indicators on the package and on the UPS.

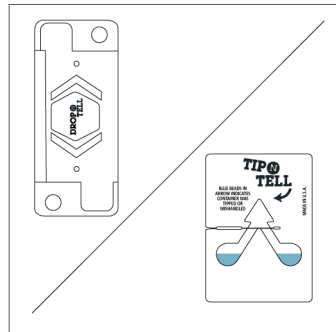

3. Open the UPS package.

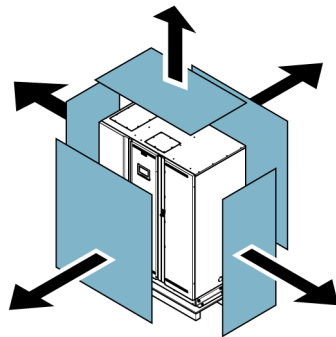

4. Remove the bolts on both sides that fasten the shipping brackets to the cabinet and to the pallet.

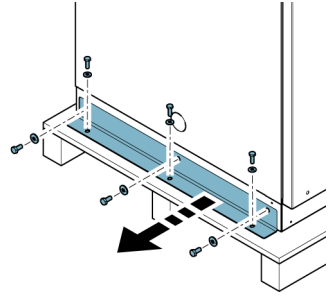

Note: After you have removed the shipping brackets, move the unit immediately away from the pallet.

5. Use a forklift to raise the unit while it is still on the pallet.

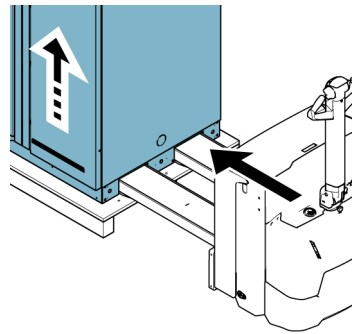

6. Remove the shipping pallet.

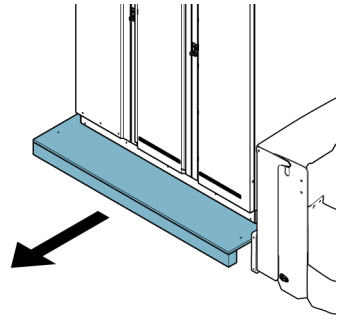

7. Move the cabinet to its final installation location.

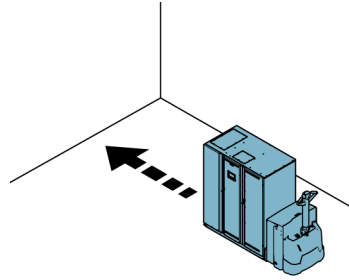

8. To secure the UPS cabinet in position, attach the shipping brackets on both sides of the cabinet with the angle facing outward. It is recommended to attach the lower cover plates to the ends of the cabinet (included in the package).

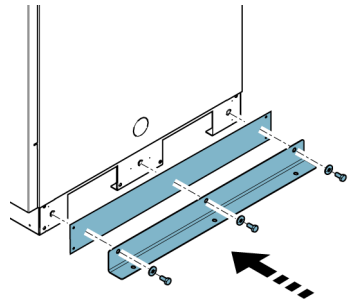

5 UPS system installation

The operator has to supply the wiring to connect the UPS to the local power source. The installation of the UPS must be made by a locally qualified electrician. The electrical installation procedure is described in the following section. The installation inspection and the initial start-up of the UPS and installing an extra battery cabinet must be carried out by an authorized Eaton Customer Service Engineer or by other qualified service personnel authorized by Eaton.



CAUTION

To avoid physical injury or death, or damage to the UPS or the load equipment, follow these instructions during the UPS system installation.



CAUTION

In case of condensed moisture inside the UPS cabinet, dry the cabinet with a blower before starting up the system.

5.1 Steps to install the UPS

Power wiring can be routed through the bottom or top of the cabinet. Control wiring can be routed through the rear, bottom, or top of the cabinet, with connections made to easily accessible terminals. See Figures 16 and 18.

The interface wiring may be wired from top of the unit using cable glands in the plate on top of the unit. Wires can be routed through the communication cable conduit.

1. Remove the left panel by loosening the screws. For units with internal MBS, remove the handles of the MBS by loosening the screw on the handle.
2. For installing the power cables and battery signal wires, remove the screws of the top or bottom cable access gland plate.
3. For installing the control wiring, use the rear communication cable conduit or route the wires through the communication cable access gland plate. See Figure 18.
4. Depending on the installation method, use the appropriate plate.
5. Route all the cables through wire way to the UPS terminal blocks.
6. Reinstall wire entry plate and install conduit if needed.
7. Route and connect power wiring. Use movable cable support beams if needed. See Figure 19.
8. When all wiring is complete, close the left panel and tighten the screws.
9. If installing a parallel system, repeat the above steps to all units in the system.

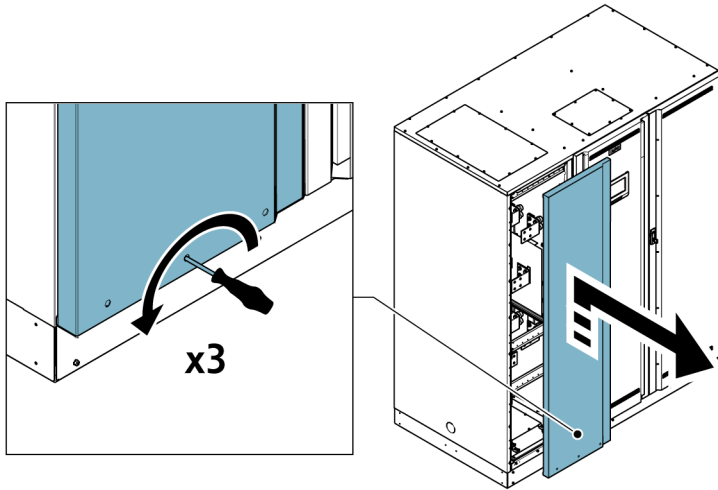

Figure 16. Removing the left panel

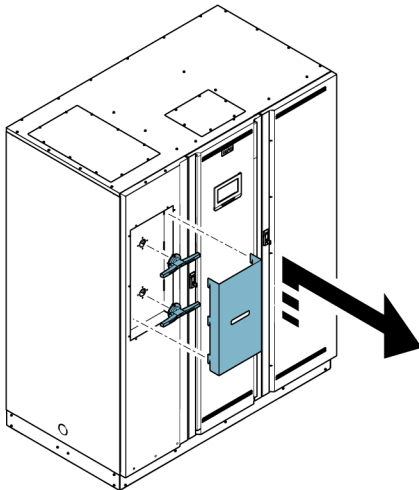

Figure 17. Removing the left panel with MBS

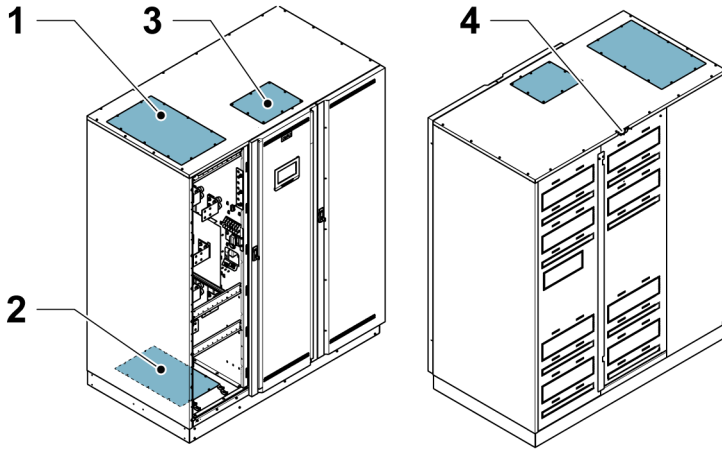

Figure 18. Gland plate locations

- | | | | |
|---|---------------------------------|---|--|
| 1 | Top cable access gland plate | 3 | Communication cable access gland plate |
| 2 | Bottom cable access gland plate | 4 | Rear communication cable conduit |

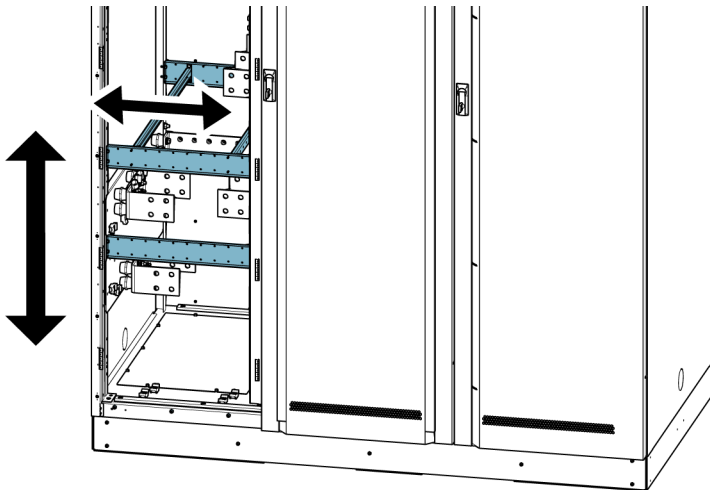

Figure 19. Cable support beams

The support beams can be moved upwards and downwards, if it is required for the cable routing.

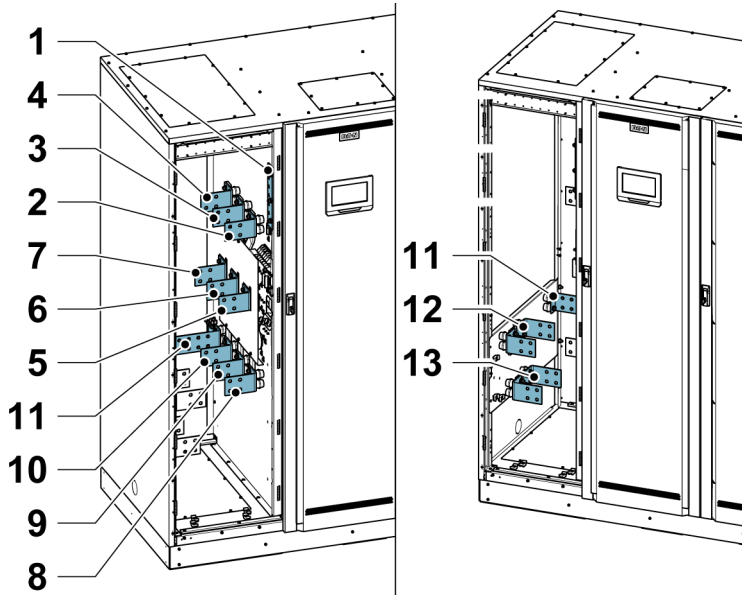

Figure 20. Connector locations

- | | | | |
|----------|---------------------------|-----------|---------------------------|
| 1 | <i>Ground</i> | 8 | <i>Bypass input L1</i> |
| 2 | <i>Rectifier input L1</i> | 9 | <i>Bypass input L2</i> |
| 3 | <i>Rectifier input L2</i> | 10 | <i>Bypass input L3</i> |
| 4 | <i>Rectifier input L3</i> | 11 | <i>Neutral</i> |
| 5 | <i>UPS Output L1</i> | 12 | <i>External battery +</i> |
| 6 | <i>UPS Output L2</i> | 13 | <i>External battery -</i> |
| 7 | <i>UPS Output L3</i> | | |

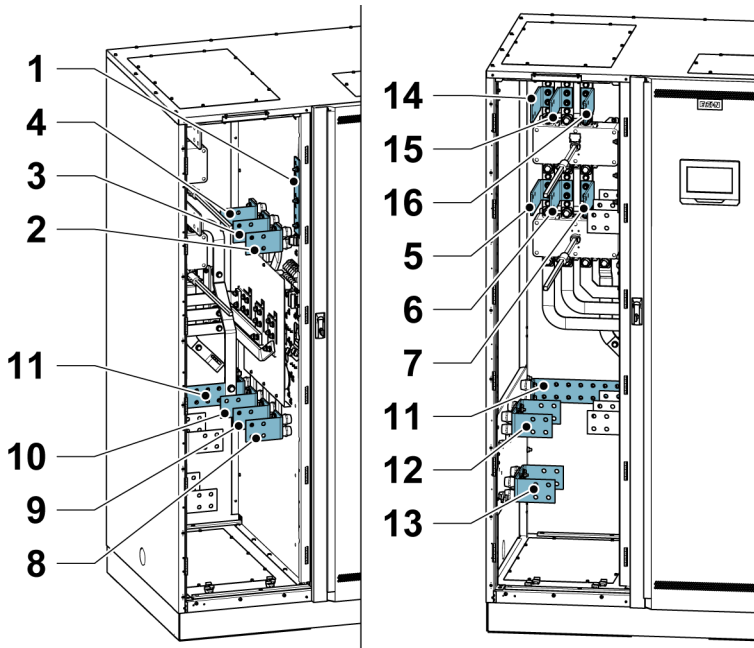

Figure 21. Connector locations with the optional internal MBS switch

- | | | | |
|----------|---------------------------|-----------|--|
| 1 | <i>Ground</i> | 9 | <i>Bypass input L2</i> |
| 2 | <i>Rectifier input L1</i> | 10 | <i>Bypass input L3</i> |
| 3 | <i>Rectifier input L2</i> | 11 | <i>X1/X2/X3/X7:N Neutral</i> |
| 4 | <i>Rectifier input L3</i> | 12 | <i>X4:BATT+ External battery +</i> |
| 5 | <i>UPS Output L1</i> | 13 | <i>X4:BATT- External battery -</i> |
| 6 | <i>UPS Output L2</i> | 14 | <i>X8:L1 Maintenance bypass input L1</i> |
| 7 | <i>UPS Output L3</i> | 15 | <i>X8:L2 Maintenance bypass input L2</i> |
| 8 | <i>Bypass input L1</i> | 16 | <i>X8:L3 Maintenance bypass input L3</i> |

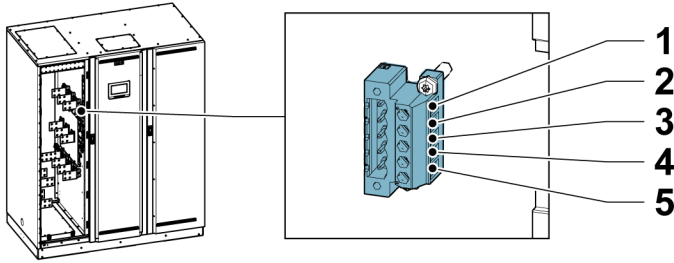

Figure 22. Battery trip wiring X6

- | | | | |
|---|-----------------------------|---|---------------------------------|
| 1 | Shunt trip (+24 V C1) | 4 | Status signal (DET 3.14) |
| 2 | Shunt trip return (TRIP C2) | 5 | Status signal return (GND 3.13) |
| 3 | Not in use | | |

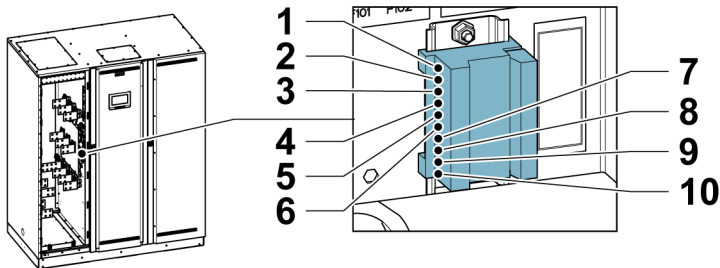

Figure 23. Sync control interface X11 details

- | | | | |
|---|-----------|----|-------------------|
| 1 | BYPASS L1 | 6 | OUT L3 |
| 2 | BYPASS L2 | 7 | Not in use |
| 3 | BYPASS L3 | 8 | Sync signal in L1 |
| 4 | OUT L1 | 9 | Sync signal in L2 |
| 5 | OUT L2 | 10 | Sync signal in L3 |

5.2 Installing the battery system

DANGER



This UPS may have internal batteries. The batteries are designed to deliver a large amount of energy and an incorrect connection may lead to a short circuit and cause serious injuries to the personnel or damages to the equipment. In order to avoid damages to the equipment or injuries to

personnel, only commissioning personnel are allowed to perform the connection of these batteries.

If you are installing a customer-supplied battery system, install the battery system according to the battery and battery system manufacturer's instructions and all the applicable national codes and regulations. Only qualified personnel may install the battery system. Battery cables must be protected against current and thermal overload, that is, the battery system must include proper fuses or breaker with protection function. Ground the external battery cabinet to the UPS.

The default battery settings of the UPS are for 12 V VRLA batteries. If you need to use any other type of batteries, contact your Eaton representative. See Section [9.5](#) for the battery specification.

5.2.1 Battery trip wiring

The external battery breakers can be tripped (switched off) by energizing its shunt trip coil. The shunt trip coils are energized (controlled) through connector X6. The status signal of the external battery breaker is also connected to connector X6. This connector is internally wired to the signal input number five. Status contacts of the Eaton battery breakers are open if the breaker itself is open.



Note: The default voltage of the battery breaker shunt trip coil is 24 Vdc. For a 48 Vdc shunt trip, contact an authorized Eaton Customer Service Engineer.

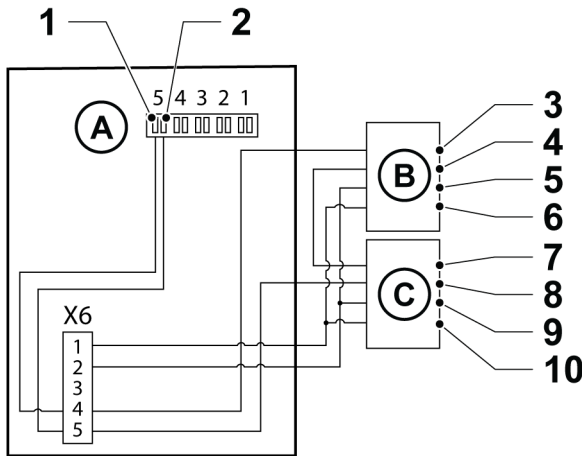

Figure 24. Battery trip wiring for 93PM UPS

A	Signal inputs	5	Shunt trip coil -
B	External battery breaker	6	Shunt trip coil +
C	External battery breaker	7	Aux contact return
1	Signal input 5 return	8	Aux contact
2	Signal input 5	9	Shunt trip coil -
3	Aux contact return	10	Shunt trip coil +
4	Aux contact		

5.3 Installing UPS external battery cabinet and battery power cabling

For the 93PM product line, there are two different battery cabinets available: EBC-C and EBC-D. The 93PM 500 kVA and the 400 kVA UPSs use 40 battery blocks per string, and the 400 kW UPS uses 36 or 40 battery blocks per string. See a separate manual for instructions on how to install Eaton external battery cabinets.



Note: Do not connect battery strings with different battery quantity and voltage in parallel.

Cable entry to the UPS is always on the top or the bottom of the cabinet.



Note: If batteries are wired outside the cabinets, follow the installation instructions given in Section [4.3.2](#).

5.4 Installing a remote EPO switch

A remote EPO switch can be used in case of an emergency to shut down the UPS and remove power to the critical load from a location away from where the UPS is installed.

EPO is connected to the UPS's top front panel, on connector EPO. Figure 25 shows the NO and NC connections of the EPO switch.

EPO connector (front view):

- A = Normally open
- B = Normally closed

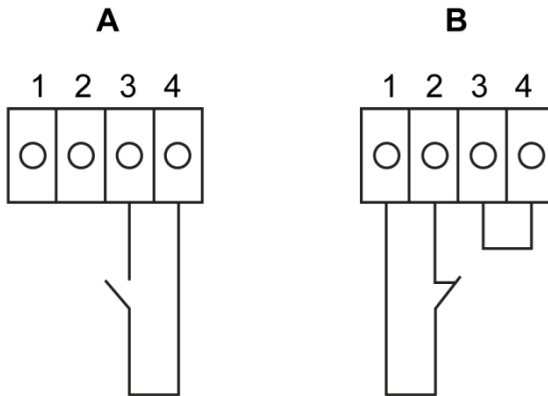

Figure 25. Connections of the EPO switch. Note that in "Normally closed" (B) situation a jumper between pins 3 and 4 is needed.

Table 16: Remote EPO wire terminations

From remote EPO switch	To user interface terminal block EPO in UPS cabinet	Remarks
NO	3-4	
NC	1-2	Wire jumper between 3-4 must be installed for proper functions

5.5 Installing interface connections

93PM UPS contains a total of five (5) signal input connectors for customers which can be used for giving remote control commands to the UPS. Customer interface connector CN5 can be used for these purposes. Each input is a dry relay contact input and requires two wire signaling. None of the inputs are pre-

programmed but need to be separately programmed by qualified service personnel.



Note: When using an external battery system, Eaton recommends you to connect external signal wiring.

There is also one general alarm relay output on the front panel. This output is either normally open (NO) or normally closed (NC). Polarity selection is made with wiring connection. By default, the general alarm relay activates when a system alarm is active, that is, any ALARM condition in the system is active. Alternatively, it can be activated with any particular event but this must be programmed separately by qualified service personnel. The alarm relay is designed for signal level (ELV or SELV) voltages only, not for utility use. For higher signaling circuit voltage requirements, please use Industrial Relay Adapter in MiniSlot.

5.5.1 Installing customer input signals interface

These inputs are located behind the UPS door, in the top section of the UPS. See Figure 28 for the connector locations.

Tie points with strain relief for the communication cables are located on the right and left side of the cable conduit.

Signal inputs can be configured to different functions. Normally these functions are either informative (for example, “On Generator”) or functional (for example, a remote “Go to bypass” command).

5.5.2 Battery breaker wiring interface

When using the original accessory battery cabinet from the manufacturer, the battery breaker interface wiring is provided with the cabinet. The wiring is connected to the X6 terminal in the UPS.

When using a third-party battery system, the breaker must be equipped with auxiliary signal and should have a 24 Vdc shunt trip for remote opening of the breaker, when needed.

See Section 5.2.1 for installation instructions.

5.5.3 Relay output interface connections

The general alarm relay is a dry relay signal output. The relay can be used for informing the operators about UPS alarm conditions, for example through a building management system. By default, the relay is configured to activate when the UPS general alarm is active, that is, any event when the *ALARM* status is active. The relay can also be configured to activate by some other event, but this needs to be done by authorized service personnel.

Relay signal wiring can be installed only through the signal cabling canal, from back to front, in the top section of the UPS.

Additional relay outputs are available with mini-slot cards. Relay outputs can be configured to be activated by various events. Configuration can be done by an authorized Eaton Customer Service Engineer or by other qualified service personnel authorized by Eaton.

5.5.4 Industrial Relay Card interface connections

Relays K1 through K5 are identical in function. Each output contact function can be assigned by the user. The UPS information may also be configurable.

To install the INDRELAY-MS:

1. Check that the ancillary equipment system is turned off and all the power sources are removed. Refer to the appropriate operation manual of any ancillary equipment for shutdown instructions.
2. Install wiring from the IRC to the monitoring equipment using appropriate conduits through the cable exit opening in the IRC.
3. Connect wiring between the IRC terminal blocks and the monitoring equipment using terminations. Connect one wire to COM (Common) and another to either NC or NO to select the Normally Open or Normally Closed option.
4. Install the INDRELAY-MS into an open MiniSlot communication bay in the UPS cabinet.

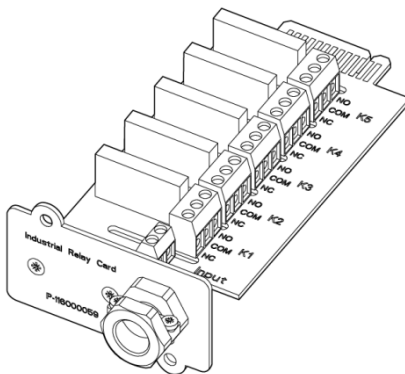

Figure 26. Industrial Relay Card INDRELAY-MS

5.5.5 MiniSlot interface connections

For MiniSlot accessories and communication devices selection, see Chapter 6. For installation and setup of a MiniSlot card, please contact your Eaton representative.

To install wiring to the connections:

1. If not already installed, install the LAN drops.
2. Open the front door of the UPS.
3. To remove the MiniSlot cover plate, remove the 2 screws securing the plate.
4. To install the MiniSlot communication device, push it all the way in.
5. Secure the MiniSlot communication device with 2 screws.
6. Route and install the LAN and other cables to the appropriate MiniSlot cards. The cable route is through the signal cable canal in the top section of the UPS.
7. For operator instructions, refer to the manual supplied with the MiniSlot card.
8. When all the wiring is completed, close the front door and secure it with the latch.

5.5.6 Installing signal interface connections in a parallel system

The installation of the signal interface connections in a parallel system is done by following the aforementioned instructions. Signal inputs can be paralleled between the units, that is, the same contact can be used for several units' signal input signaling. This concerns also the EPO signal.

5.6 Wiring parallel 93PM UPS systems

The outputs of multiple 93PM UPS systems can be connected in parallel. Up to 4 units can be paralleled. The UPS static bypass power rating needs to be identical among all the paralleled units. However, paralleled UPS cabinets can be housed with different number of UPM power modules.

The outputs are paralleled to increase the load capacity of the power system and for redundancy. The system is paralleled for (N+1) redundancy, as long as there is always one or more UPS online than required to support the load. The system is paralleled for capacity if all UPSs in a system are required to support the load.

Communication between the UPSs is required for system metering and mode control. The system level communication and control are accomplished using a Controller Area Network (CAN). A pull-chain signal in each UPS, connected to the other UPSs in parallel and tied to the bypass status relay in each UPS, is used for a secondary communication path. This arrangement ensures bypass control even if the CAN bus is lost.

WARNING

Do not connect units equipped with an internal Maintenance Bypass Switch (MBS) or internal transformers in parallel.



5.6.1 Power wiring overview

See Section [4.3.2](#) for the recommended cable and external fuse sizes and installation practices.

Input feed

The input feed is defined as the power source connected to the UPS rectifier. The feed to all UPS's inputs must be derived from the same source.

Bypass feed

The bypass feed is defined as the power source connected to the UPS bypass. The feed to all UPS's bypass must be derived from the same source. The shortest length of power wire from the source to the UPS must be a minimum of 95% of the length of the longest wire.

Output

The neutrals of all the UPSs must be connected. The shortest length of wire from the source to the UPS must be a minimum of 95% of the length of the longest wire. The measurement is with respect to where the UPS's outputs are tied.

Dual source

The input feed and bypass feed may be separate sources. The sources must share a common neutral.

Battery connection

A separate battery shall be connected to each UPS, and the battery capacity for each UPS must be identical. A common battery for all UPSs is not supported.

MOBs

Module Output Breakers (MOBs) allow the output of an UPS to be disconnected from other UPSs and the system load for maintenance and service. Design considerations assume that each UPS has a Module Output Breaker (MOB). The breaker should also disconnect the neutral for improved safety during maintenance.

The MOB must have a Form "C" auxiliary contact. The N.C contact is connected to the corresponding UPS's input used for signal input. The N.O. contact is used to disconnect the bypass pull-chain when the MOB is open. Figure [27](#) shows the principles of paralleled UPS systems including MOBs and outputs from UPSs.

MOB override

Users without MOBs installed can simply leave the MOB signal input disabled. The user should be aware that systems without MOB have limited maintenance capability.

Parallel system cabling

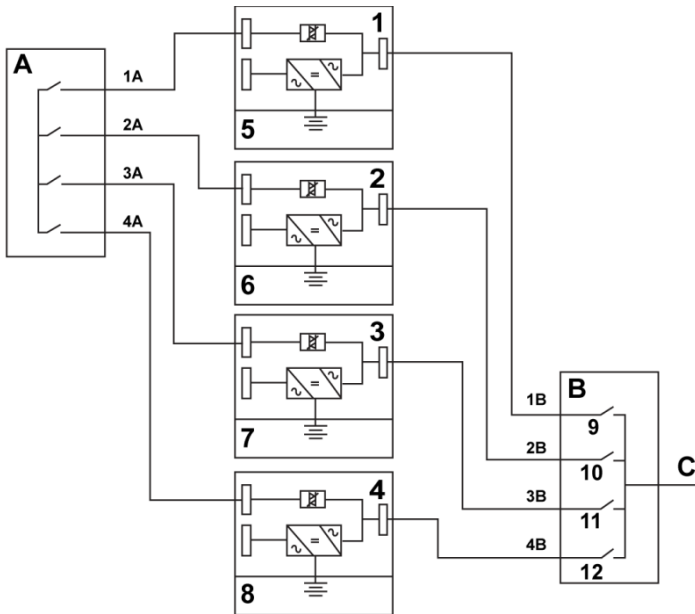

Figure 27. Principle of paralleled UPS systems

A	Bypass inputs to UPSs	1	UPS 1	7	Battery
B	Outputs from UPSs	2	UPS 2	8	Battery
C	Load	3	UPS 3	9	MOB1
		4	UPS 4	10	MOB2
		5	Battery	11	MOB3
		6	Battery	12	MOB4

The required parallel system wiring length must be equal to ensure approximately equal current sharing when in the bypass mode.

For proper operation, the following must be true: $1A+1B=2A+2B=3A+3B=4A+4B$.

Any differences in wire length result in decreased capacity and improper operation of the UPS system while in the bypass mode.

5.6.2 Control signals overview

Two controls signals (External CAN Network, Bypass Pull-Chain) are required for external paralleling. Both of these control signals are fault-tolerant and alarmed when disconnected.

External CAN (ECAN)

ECAN provides a means for communication between the UPSs in a parallel system. The system will continue to share load and protect the load when this network fails

Bypass Pull-Chain

Bypass Pull-Chain is an open collector signal that goes low when the bypass static switch of any UPS is online. When External CAN (ECAN) is down, the pull-chain is low and the UPS is online, the UPS locks to and transfers to the bypass mode. Service personnel can manually short this signal in some rare failure modes to force the system transfer to bypass.

Signal Inputs Actions

Each UPS has maximum 8 signal inputs, 5 native and 1 in each MiniSlot when using a suitable connectivity device. These inputs can be configured with action items. The following action items affect all the UPSs in the system. When an action item is active on a UPS and the MOB is closed, the action item is transmitted on the ECAN to all the UPSs. All the UPSs react in the same manner as if the action item was active on that UPS.

Wiring the EPO switch in parallel

It is recommended to use separate EPO circuits for each parallel unit.

5.6.3 Installing bypass control wiring

- During the installation, follow all the safety instructions given in this document.
- A 12-pin terminal block for external parallel control signals is accessible on the right side of the communication interface, on the top section of the UPS (see Figure 28).
- The Phoenix Contact FRONT-MSTB 2,5/12-STF-5,08 plug component shall be used for cable wiring termination.

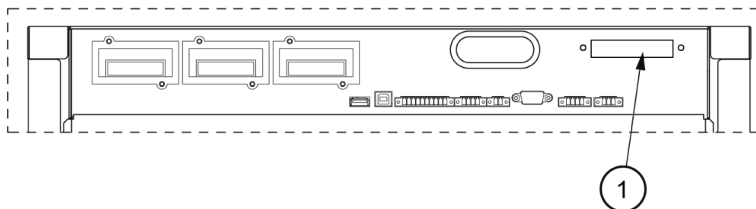

Figure 28. Communication interfaces

- 1 External parallel connector

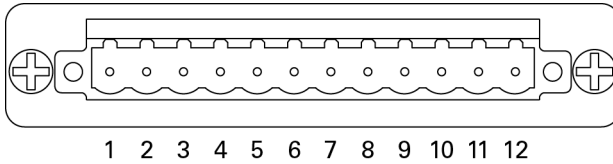

Figure 29. External parallel connector

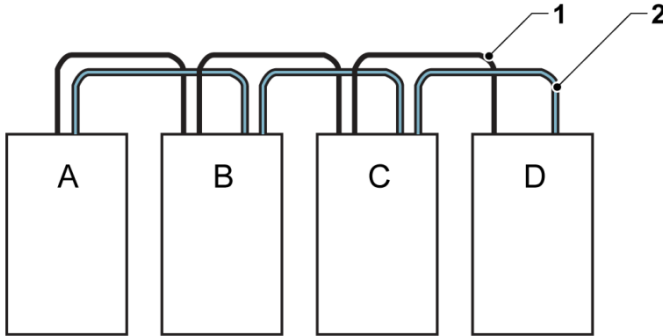

Figure 30. Simplified CAN and Pull-Chain wiring for parallel UPS system

A	UPS 1	1	CAN
B	UPS 2	2	Pull chain
C	UPS 3 (if installed)		
D	UPS 4 (if installed)		



Note: This drawing is for distributed bypass wiring purposes and it is not a floor layout plan. UPSs can be placed in any physical order.

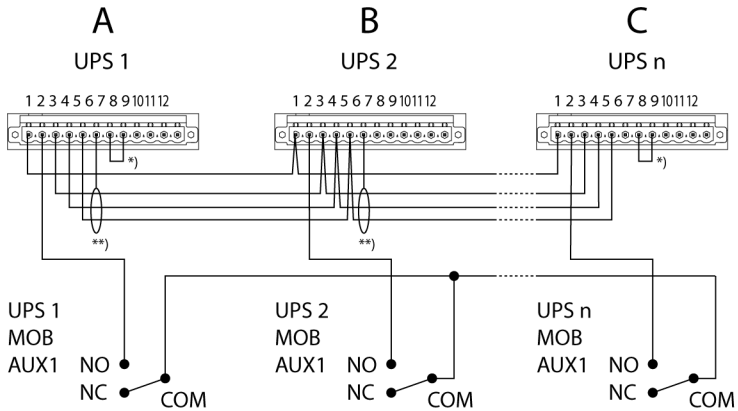

Figure 31. CAN and Pull-Chain wiring for parallel UPS with MOBs

Note that the shield cable must be connected on one end only.

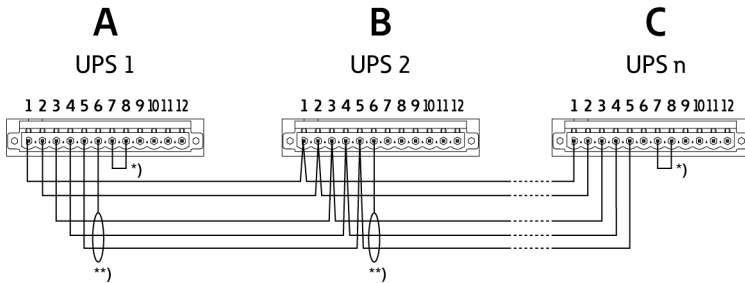

Figure 32. CAN and Pull-Chain wiring for parallel UPS without MOBs

- | | | | |
|----------|------------------------------------|-----------|---|
| A | External parallel connector, UPS 1 | 5 | GND (ISP) |
| B | External parallel connector, UPS 2 | 6 | Earth |
| C | External parallel connector, UPS 3 | 7 | CANBL |
| 1 | External pull chain | 8 | CANB_1 |
| 2 | GND-S | * | Terminate the first and last UPS with a jumper. |
| 3 | CANBH | ** | Connect the shield from one end only. |
| 4 | CANBL | | |



Note: NC and NO designations on MOB AUX contacts are defined with the breaker in the OFF (open) position. If the MOB contacts have pigtail leads, use the same wire gauge to connect to the UPS and use the correct crimp

connections for the wire gauge. External CAN connections between the UPS cabinets require shielded twisted pair wire. Use twisted pair wiring between the UPS and MOB AUX contacts. Always confirm contact operation prior to wiring.

5.7 UPS system interface wiring preparation

Control wiring for features and options should be connected at the customer interface terminal blocks located on top front of the UPS, behind the door.



Note: Do not connect relay contacts directly to the mains-related circuits. Reinforced insulation to the mains is required.

Read and understand the following notes while planning and performing the installation:

- The customer must provide all interface wiring.
- When installing internal interface wiring to MiniSlot terminals, route the wiring through the internal opening in the MiniSlot communication bay.
- All signal inputs or remote features require an isolated normally open contact or switch (rated at 24 Vdc, 20 mA minimum) connected between the alarm input and common terminal. All control wiring and relay and switch contacts are customer-supplied. Use twisted-pair wires for each alarm input and common.
- The signal inputs can be programmed to display the alarm functional name.
- LAN and telephone drops for use with MiniSlot cards must be provided by facility planners or the customer.
- The UPS Battery Aux and 24 Vdc Shunt Trip signal wiring from the UPS must be connected to the DC source disconnect device. Also 48 Vdc Shunt Trip signal can be utilized. See Figure 24.
- Battery Aux and Shunt Trip wiring should be a minimum of 1.5 mm².
- The Remote EPO feature opens all switchgear in the UPS cabinet and isolates power from your critical load. Local electrical codes may also require tripping upstream protective devices to the UPS.
- The Remote EPO switch must be a dedicated switch not tied to any other circuits.
- A jumper wire must be connected between pins 1 and 2 on connector EPO, if the normally-closed (NC) Remote EPO contact is used.
- Remote EPO wiring should be a minimum of 0.75 mm² and a maximum of 2.5 mm².
- The distance between the Remote EPO and the UPS cannot exceed 150 meters.
- Alarm relay contacts have a maximum current rating of 5 A and a switched voltage rating of 30 VAC (RMS) and 30 Vdc.

- Alarm relay wiring should be a minimum of 0.75 mm².

6 Communication interfaces

This section describes the communication features of the Eaton 93PM UPS.

CAUTION



All the communication interfaces are SELV circuits. When connecting to other equipment, make sure that you maintain this characteristic.

The UPS has the following communication interfaces:

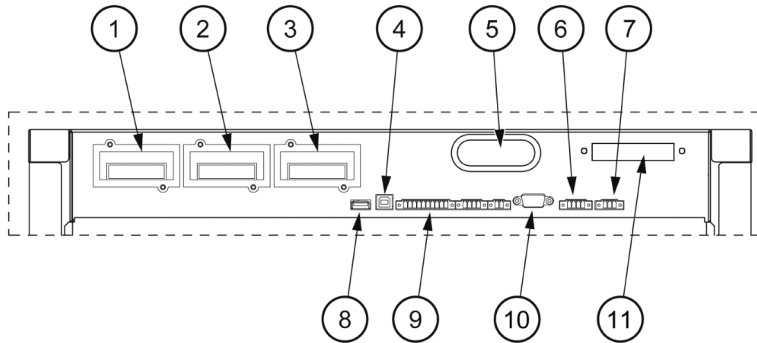

Figure 33. Communication interfaces

1. MiniSlot 1
2. MiniSlot 2
3. MiniSlot 3
4. USB device (connection to computer)
5. Communication cable conduit
6. Emergency Power Off (EPO)
7. Relay output
8. USB host (connection to accessories)
9. Signal inputs
10. RS-232 port for service
11. External parallel connector

6.1 MiniSlot cards

The Eaton 93PM UPS has three Mini-slot communication bays. For instructions on how to install a MiniSlot card, see [5.5.5](#).

The UPS is compatible with the following MiniSlot cards:

- Network Card-MS

Provides remote monitoring through a web browser interface, e-mail, and a network management system (NMS) using SNMP and connects to a twisted-pair Ethernet (10/100BaseT) network.

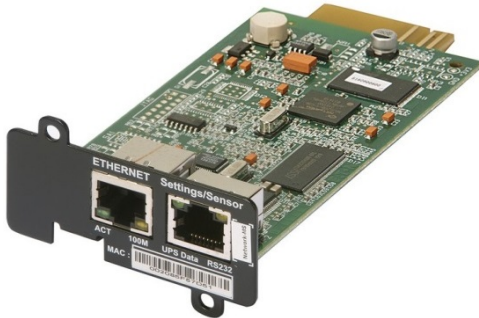

Figure 34. Network Card - MS

- PX Gateway Card

Provides remote monitoring through a Web browser interface, e-mail, and a network management system (NMS) using SNMP and connects to a twisted-pair Ethernet (10/100BaseT) network. The card also provides direct integration of UPS information (meters and status) to a Building Management System (BMS) using the Modbus RTU and TCP protocols as well as BACnet protocols.



Figure 35. PX Gateway Card

- Industrial Relay Card-MS

The MiniSlot Industrial Relay Card provides a way of connecting the UPS to industrial and electrical monitoring systems. It also enables a wide range of control applications by allowing up to 250 volts and 5 Amperes through its 5 relay connections. By connecting wires to the corresponding places in its terminal blocks, you can choose Normally Open or Normally Closed setup for each output.

For information on how to configure Industrial Relay Card-MS, see Section [6.5](#).

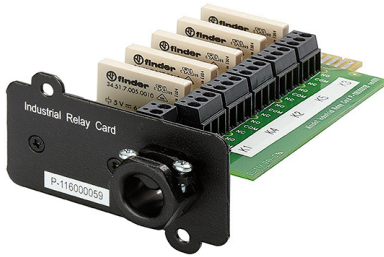

Figure 36. Industrial Relay Card-MS

6.2 Intelligent Power Software

Intelligent Power Software are productivity tools for UPS power management. These software solutions enhance the protection provided by a UPS by shutting down applications and operating systems, triggering disaster recovery procedures and migrating virtual machines in case of an extended power outage. They also help in reducing downtime and increasing the reliability of the UPS by alarming the operators of issues and monitoring vital meters. The software can also be used to view the usage characteristics of power equipment across the enterprise and use the data to optimize the use of the facilities.

Intelligent Power Software is web-based, which means that the information can be accessed through any device that has a web browser.

On one hand, Intelligent Power Manager (IPM) is a monitoring system that can concentrate the data and alarms of hundreds of UPS, ePDU and other devices into a single view. On the other hand, it provides a link to virtualization through management systems, such as VMware vCenter. This way an administrator gets a single pane of glass to manage both IT equipment and the supporting infrastructure. IPM provides the shutdown, migration, disaster recovery and load shedding features in virtualized environments.

Intelligent Power Protector (IPP) is a shutdown agent with basic monitoring and alarming capability. It provides automatic, graceful shutdown of computers and virtual machines or servers powered by an Eaton UPS during a power outage that lasts longer than your available battery runtime. Intelligent Power Protector can be remotely supervised and managed by the Intelligent Power Manager (IPM) application.

Intelligent Power Software is delivered on a CD with the UPS. Alternatively, you can download it from the Eaton web page. Some of the advanced features of IPM require a license, contact your Eaton representative for details.

6.3 Signal input monitoring

This standard feature lets you connect smoke detectors or over-temperature alarms to your signal inputs. The user interface terminals for external connections are located inside the UPS. Use twisted-pair wires for each alarm input and common.

The signal inputs can be programmed to display the alarm functional name. See list of Signal input functions in Appendix A: Relay alarms.

6.4 General purpose relay contact

One general purpose relay contact is provided as a standard feature on the UPS. An alarm contact is also provided.

You can use a normally-closed or normally-open contact. If the state of the contact changes from the state you specify as normal, a signal is issued. You can connect this contact to equipment at your facility (such as a light or an alarm bell) to let you know when an alarm is active on the UPS. This feature is useful if the UPS is located in a remote area where the UPS horn may not be heard immediately.



Note: Do not operate the contacts in excess of 30 VAC (RMS) and 30 VDC at 5 A maximum.

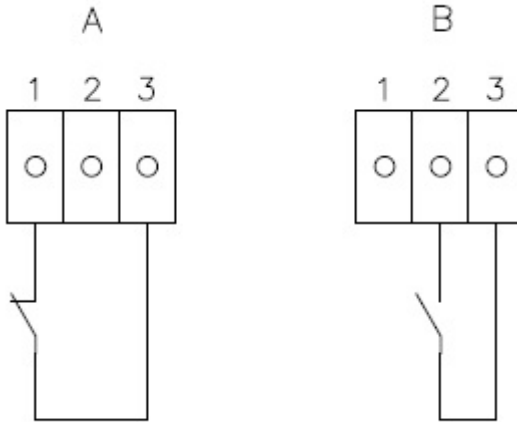

Figure 37. Output relay configurations: A) Normally closed (pins 1 and 3), B) Normally open (pins 2 and 3)

6.5 Configuring relays

93PM offers one native relay output. Additionally, each of the 3 MiniSlots can be equipped with a 5-relay adapter for additional relay outputs. The following instructions guide you through the relay configuration.

The relay configuration can be done via the display. See Appendix A: Relay alarms for available nodes that can be configured to relays.

The maximum voltage of the relay is 30 V. Check the voltage and current specifications of the other cards from the previous sections.

The process for relay configuration is as follows:

1. In the home screen of the display, click the lock icon in the top right corner to type in the service password.
2. In the sign in window, click the password field containing the 4 dots.



Figure 38. Sign in window with the password field

3. Enter the password 0101 and press .
4. Select **Continue**.
5. Select **Configuration** and then **Relays Outputs**.

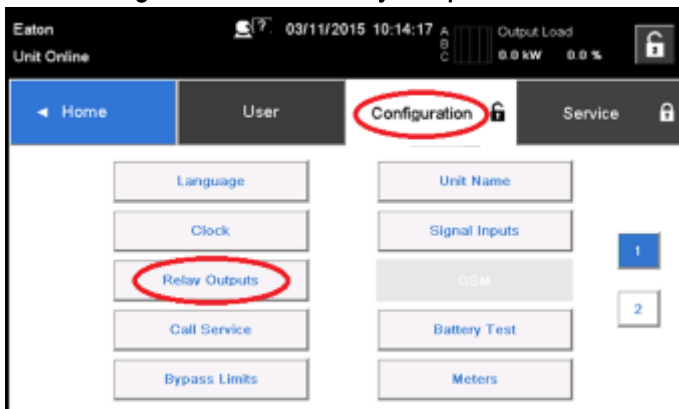

Figure 39. Selecting Relay Outputs in the Configurations screen

6. Select out of the following options:
 - Native (Alarm) relay
It is possible to set 8 different events for the native relay. If any of the set events occurs, the relay is activated
 - MiniSlot 1
 - MiniSlot 2
 - MiniSlot 3

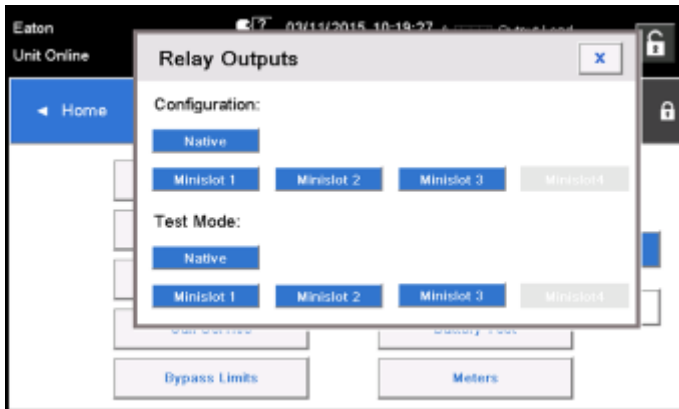

Figure 40. Options for relay outputs configuration

7. Enter the code(s) of the function(s) that you want to trigger the relay when they become active.
8. Press **OK** and **Save** to save the changes.

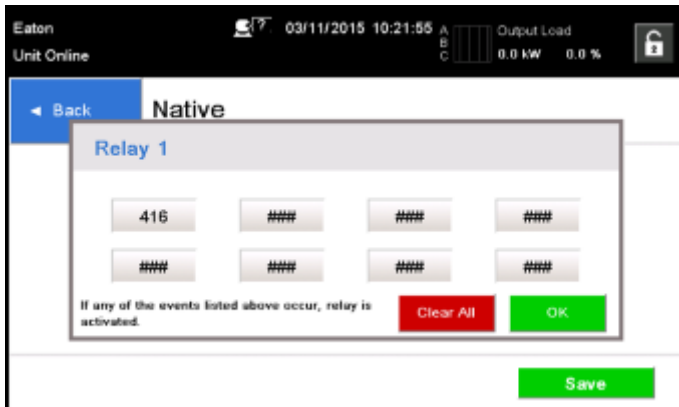

Figure 41. Entering the codes of the functions that will trigger the relay

9. If you selected one of the MiniSlots, the following default values are available:
 - Relay 1: #262 On Line (LED is lit)
 - Relay 2: #260 On Battery (LED is lit)
 - Relay 3: #352 Alarm (LED is lit)
 - Relay 4: #261 On Bypass (LED is lit)
 - Relay 5: #15 Low Battery warning

Alternatively, you can configure the relays with any event you want.

10. You can test the relays by selecting any of the options in the test mode (see Figure 40).

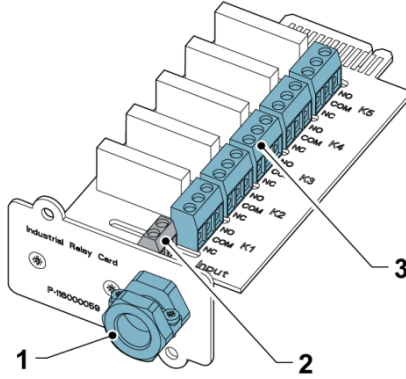

Figure 42. Relays

- | | |
|--|---|
| <p>1 Cable exit opening for up to 12 mm ($\frac{1}{2}$" conduit</p> <p>2 Signal input connector with voltage supply</p> | <p>3 K1 thru K5 terminal connections for relay contacts to operator's monitoring equipment</p> |
|--|---|

7 UPS operating instructions

This section describes how to operate the UPS.



CAUTION

Before you operate the UPS, make sure that all the installation tasks are completed and a preliminary startup has been performed by authorized service personnel. The preliminary startup verifies all the electrical interconnections to make sure that the installation was successful and the system operates properly.

Before you operate any of the controls, read these instructions and have a thorough understanding of the UPS operation.

The UPS is configured to operate with one of the following nominal voltages: 380, 400, or 415 VAC. Before you start to operate the UPS, confirm the UPS nominal voltage and frequency from the display by selecting **Settings > Information**. If the UPS need to be operated with another voltage or frequency, contact your closest Eaton office or Eaton authorized partner.



Note: The UPS is not a measuring device. All the displayed measurements are approximate values only.

7.1 UPS controls and indicators

7.1.1 Control panel

The control panel, located on the UPS front door under a protective hatch door, contains a color touch screen display. It is used to display the status of the UPS system and control the operation of the UPS.

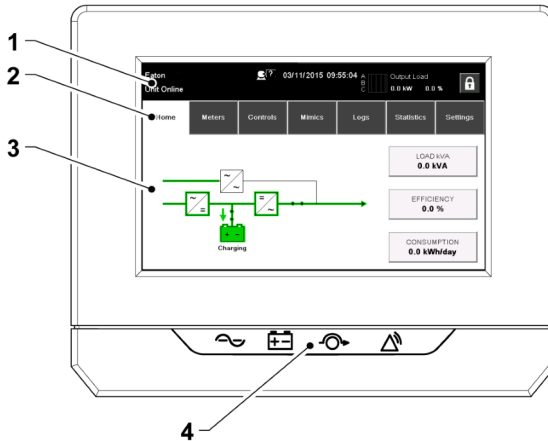

Figure 43. Parts of the display



The display consists of the following parts:



1	Status bar	The status bar displays the UPS name, state, current date and time, meters information, and a sign in/out button. It also shows any active alarms and warnings.
2	Main navigation	Select a screen by tapping on its name.
3	Content area	This is the main area for showing information on the UPS status and operations.
4	Status indicators	See Section 7.1.2 .

7.1.2 Status indicators

The four symbols below the display are status indicators. They are colored light emitting diode (LED) lamps, and they work in conjunction with the alarm horn to let you know the operating status of the UPS.

Table 17: Status indicators

Indicator	Status	Description
Green symbol for normal operation 	On	The UPS is operating normally and supplying power to the critical load.
	Off	The UPS is turned off.
Yellow symbol for battery mode 	On	The UPS is in the battery mode. Because the battery mode is a normal condition of the UPS, the green indicator for normal operation also remains illuminated.

Indicator	Status	Description
Yellow symbol for bypass mode 	On	The UPS is in the bypass mode. The critical load is supported by the bypass source. The green indicator for normal operation is not illuminated when the system is in the bypass mode.
Red symbol for active alarm 	On	The UPS has an active alarm and requires immediate attention. The screen shows the highest priority active alarms. All alarms are accompanied by an audible horn. To silence the horn, press any control panel button once. The alarm indicator may be illuminated along with other indicators.

Color LED indicators

The LED indicators consists of two rows of LEDs located on the left and right sides of the UPS cabinet door. The LEDs are red, green and yellow (RGY). The color of the LED is used to indicate the condition of the UPS. The most urgent condition is always the one shown. Only one color is shown at a time. The table below defines which color is shown.

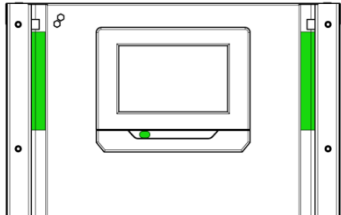
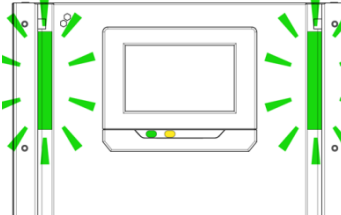
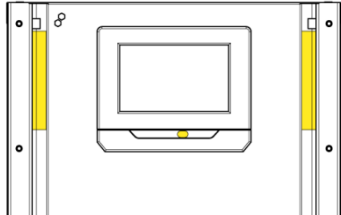
Color LED indicators (screen and door)	UPS status
	Normal operation
	Battery mode The green LEDs on the sides of the UPS cabinet door are blinking and the yellow symbol for battery mode is illuminated below the display. Since the battery mode is a normal condition of the UPS, the green symbol for normal operation is also illuminated below the display.
	Bypass mode

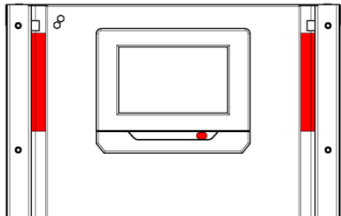
Color LED indicators (screen and door)	UPS status
	Alarm

7.1.3 System events

When the UPS system is running in the double conversion mode, it continually monitors itself and the incoming utility power. In the battery or bypass mode, the UPS may issue alarms to let you know exactly what event caused the change from the double conversion mode. System events on the UPS can be indicated by horns, lights, messages, or all three.

Select **Logs** in the home screen to look at any currently active events.

- **System event horn**
The system event horn beeps to alert the user that an event requiring attention is taking place.
- **System event indicators**
The status indicators on the UPS control panel and the event horn let you know when the UPS system is operating in any mode other than the double conversion mode. Only the green indicator for normal operation is visible during normal UPS system operation. The other indicators illuminate to indicate alarms or events. When an alarm occurs, first check these indicators to see what type of event has taken place.
- **System event messages**
When a system event occurs, a message appears in the status bar of the display. This message is also written to the Active Events log. Some notices and alarms may be accompanied by an audible horn. To silence the horn, press any button once.

7.1.4 Menu structure of the 93PM UPS

The following table shows the menu structure of the 93PM UPS.

Table 18: Menu structure of the 93PM UPS

Main menu	Submenu	Functions
Home	-	An overview of the UPS operation, including information on load, efficiency and consumption.

Main menu	Submenu	Functions
Meters	Meters summary	A summary of the UPS or system meters.
	Input meters	Detailed information on UPS or system input meters.
	Bypass meters	Detailed information on UPS or system bypass meters.
	Output meters	Detailed information on UPS or system output meters. UPM Power
	Battery meters	Detailed information on UPS or system battery meters.

Main menu	Submenu	Functions
Controls	System controls	Go Online Go to bypass Turn Off Charger Load Off
	UPS controls	Run battery test Shut down UP
	Module controls	Start charger Run battery test Shut down module / Start module UPM 1: <ul style="list-style-type: none"> • Charger • Battery test • UPM status UPM 2: <ul style="list-style-type: none"> • Charger • Battery test • UPM status
	EAA controls	ESS: <ul style="list-style-type: none"> • Enable • Disable • Configure VMMS: <ul style="list-style-type: none"> • Enable • Disable • Configure Enable High Alert Clear status ABM: <ul style="list-style-type: none"> • Enable • Disable • Configure Clear Alarms Clear Logs

Main menu	Submenu	Functions
Mimics	UPS mimics	An overview of the UPS operation, including information on load, efficiency and consumption. If there is an error, an error indicator is displayed next to the affected part. Active events log can be opened by tapping the error indicator.
	UPS module map	Module map shows the status of each UPM.
	System overview	System overview shows the status and meters summary for each UPS.
	ESS	The ESS mimic screen shows the approximated consumption and energy savings of the ESS mode.
Logs	Active events	All active events are displayed.
	System log	A log of all system events.
	Service log	A detailed log of UPS operations.
	Change log	A log of all changed settings and their values.
Statistics: UPS, Battery	Statistics summary	A summary of UPS statistics
	Statistics details	Details are available by pressing on different statistics.
Settings	User Configuration Service	Configurable user settings.

7.1.4.1 User settings

The UPS has the following settings that are user-modifiable. In the Home screen, select **Settings**.

Table 19: User settings

Setting	Description
Information	Information on the UPS model, including part number and serial number.
About	Version information.

To modify the **Configuration** settings, you need to sign in.

Table 20: Configuration settings

Setting	Description
Language	Change the user interface language.
Unit Name	Change the unit name.
Clock	Change the date and time, change the clock format or enable/disable NTP clock setup.
GSM	GSM modem.
Call Service	Send automatic e-mail to the service center in case of a failure.

Setting	Description
Signal Input	Select signal input name and function or change contact polarity.
Relay Outputs	Configure the relay outputs.
Battery test	Change the power level and duration for battery test.
Bypass Limits	Change the bypass voltage or bypass frequency.
Screen Saver Time-out	Change the screen saver timeout.
Meters	Change the meters format.
Lamp Test	Enable the lamp test.
HMI backlight	Adjust the backlight brightness.
Control P/W level 1	Change the level 1 password, or remove the password on level 1.
Control P/W level 2	Change the level 2 password.
Reset statistics	Reset all statistics.
Minimum required kVa	Change the minimum required kVa.

7.2 Signing in

If the level 1 password is enabled, you need to sign in.

1. Press the lock icon in the top right corner of the screen.
2. Type in your password and press **OK**.
You are signed in.
3. Press **Continue** to return to the previous screen.

You have 3 attempts to type in the password. If an incorrect password is given more than 3 times, you need to wait for 30 minutes before trying again.

Table 21: Default passwords

Level	Name	Password	Description
0	USER	NONE	USER
1	CONTROL	1111	USER + CONTROL
2	CONFIGURATION	0101	USER + CONTROL + CONFIGURATION
3	SERVICE	Service Only	USER + CONTROL + CONFIGURATION + SERVICE

To modify the user settings, you need to enter the level 2 password. For the default passwords, see the table above.

7.3 System control instructions

7.3.1 Starting the UPS system in the double conversion mode

The UPS system can consist of a single UPS or several parallel UPSs. UPSs with their MOB open are not considered as part of the system.

To start the UPS system:

1. Close the UPS input feeder circuit breaker.
2. Close the UPS bypass input feeder circuit breaker.
3. Wait for the UPS control panel display to become active and to indicate logic power.
4. Repeat steps 1-3 for each individual UPS in the system.
5. In the home screen, press **Controls**.
The System controls screen appears.
6. In the System controls screen, make sure that the system status is **SHUTDOWN**.
7. In the System controls screen, press the **Go online** button.
If Auto Bypass is enabled (factory default), the critical load is immediately supplied by the bypass source, in the bypass mode, until the inverter turns on and the UPS transfers to the double conversion mode. The status indicator on the UPS control panel indicates that the UPS is in the bypass mode. If auto bypass is not enabled, the UPS output remains off until the UPS system transfers to double conversion mode.
8. Wait for the following messages to appear sequentially on the System controls screen:
STARTING
ONLINE
The rectifier and inverter turn on. The DC voltage continues to ramp up to full voltage. Once the DC link reaches full voltage and the battery breaker is closed, the UPS output relay K3 closes and the static switch turns off. Power is now supplied to the critical load in the double conversion mode. It takes approximately 20 seconds for the UPS system to achieve the double conversion mode.

The UPS system now operates in the double conversion mode. The green status indicator for normal operation is lit in all the UPSs in the system.

7.3.2 Starting the UPS system in the bypass mode

CAUTION

In the bypass mode, the critical load is not protected from mains power interruptions and abnormalities.



If the inverter output of the UPS is not available and the critical load needs to be energized, do this:

1. Close the UPS input feeder circuit breaker.
2. Close the UPS bypass input feeder circuit breaker.
3. Wait for the UPS control panel to become active and indicate logic power.
4. Repeat steps 1-3 for each single UPS in the system.
5. In the home screen, press **Controls**.
The System controls screen appears.
6. In the System Controls screen, make sure that the system status is **SHUTDOWN**.
7. In the System controls screen, press the **Go to bypass** button.
The critical load is immediately supplied by the bypass source, in the bypass mode.

The UPS system now operates in the bypass mode. The yellow bypass status indicator is lit.

7.3.3 Transferring from the bypass mode to the double conversion mode

To transfer the critical load to the double conversion mode, perform the following procedure:

1. In the home screen, press **Controls**.
The System controls screen appears.
2. In the System controls screen, press the **Go online** button.
The UPS system transfers to the double conversion mode. If there is not enough UPM capacity available, the system remains in the bypass mode and an alarm sounds.

The UPS is now operating in the double conversion mode. The green status indicator for normal operation is illuminated. The system status is shown as **UNIT ONLINE**.

7.3.4 Transferring from the double conversion mode to the bypass mode

CAUTION



In the bypass mode, the critical load is not protected from mains power interruptions and abnormalities.

To transfer the critical load to the bypass mode, perform the following procedure:

1. In the home screen, press **Controls**.
The System controls screen appears.

2. In the System controls screen, press the **Go to bypass** button.
The UPS system transfers to the bypass mode and the critical load is immediately supplied by the bypass source. If the bypass source is not available, the power processor remains on and an alarm sounds.

The UPS system is now operating in the bypass mode and the yellow bypass status indicator is illuminated. The UPM status is shown as **Ready**. The system status is shown as **ON BYPASS**.

7.3.5 Transferring from the double conversion mode to the Energy Saver System mode



Note: Note that the Energy Saver System mode commands are displayed only if enabled at the factory or by an authorized Eaton Customer Service Engineer .

To transfer the critical load to the Energy Saver System mode:

1. In the home screen, press **Controls**.
2. Select **Service controls**.
3. Select **Enable ESS**.

The entire UPS system transfers to the Energy Saver System mode and the critical load is supplied by the bypass source. If the bypass source is not available or the conditions are not correct for the ESS mode, the power module remains on and an alarm sounds. The green status indicator for normal operation is illuminated. The UPS status is shown as **UNIT ONLINE** , **ESS**. The UPM status is shown as **READY**.

7.3.6 Transferring from the Energy Saver System mode to the double conversion mode



Note: Note that the Energy Saver System mode commands are displayed only if enabled at the factory or by an authorized Eaton Customer Service Engineer.

To transfer the critical load to the double conversion mode:

1. In the home screen, press **Controls**.
2. Select **Service controls**.
3. Select **Disable ESS**.

The UPS system transfers to the battery mode and then to the double conversion mode. If the power module is not available, the system remains in the bypass mode and an alarm sounds. The green status indicator for normal operation is illuminated. The UPS status is shown as **UNIT ONLINE**. The UPM status is shown as **ACTIVE**.

7.3.7 Shutting down the UPS system and critical load

To perform maintenance or service on the critical load, shut down the power to the load by performing the following procedure:

1. Turn off all the equipment that is powered by the UPS system.
2. Perform the LOAD OFF procedure (see Section 7.3.8).
The input, output, and bypass backfeed contactors open, the battery breaker or disconnect is tripped, and the power module is turned off.
3. Open the UPS input and bypass feeder circuit breakers.
4. Repeat the steps for all the UPSs in the system.



DANGER

Power is still present inside each UPS cabinet until the upstream feeder circuit breaker is opened, and in case of a parallel system, the output is isolated or parallel units are shut down as well.

7.3.8 De-energizing the critical load

Initiate a UPS system Load Off by pressing the **Load Off** button in the **Controls > System Controls** screen. This button can be pressed to control the UPS output. The **Load Off** button de-energizes the critical load and shuts down the UPS system. The UPS system (including bypass) remains off until it is restarted.

1. Press **Load Off**.
The shutdown screen appears, providing a choice to proceed or abort the shutdown.
2. To shut down the UPS, press **Load Off**. To abort the shutdown, press **Abort**.



Note: All power to the critical load is lost when Load Off is selected. Only use this feature when you want to de-energize the critical load.

When **Load Off** is selected, the input, output, and bypass backfeed contactors open, the battery breaker or disconnect is tripped, and all the UPSs in the system are turned off.

To restart the UPS system, follow the procedure in Section 7.3.1 or Section 7.3.2.

CAUTION



Do not attempt to restart the system after Load Off until you have identified and cleared the cause of the shutdown.

7.4 Controlling a single UPS in a parallel system

7.4.1 Starting a single UPS

Make sure that the load level does not exceed the single UPS capacity.

To start the UPS:

1. Close the UPS input feeder circuit breaker.
2. Close the UPS bypass input feeder circuit breaker.
3. Wait for the UPS control panel display to become active and indicate logic power.
4. In the home screen, press **Controls**.
5. Press the **UPS controls** button.
In the UPS controls screen, the system status is shown as **SHUTDOWN**.
6. In the UPS controls screen, press the **Go online** button.
If Auto Bypass is enabled (factory default), the critical load is immediately supplied by the bypass source in the bypass mode, until the inverter turns on and the UPS transfers to the double conversion mode. The yellow status indicator on the UPS control panel indicates that the UPS is in the bypass mode. If auto bypass is not enabled, the UPS output remains off until the UPS system transfers to the double conversion mode.
7. In the UPS control screen, press the **Go online** button.
8. Wait for the following messages to appear sequentially on the UPS status line:

STARTING

ONLINE

The rectifier and inverter turn on. The DC voltage continues to ramp up to full voltage. Once the DC link reaches full voltage and the battery breaker is closed, the UPS output relay K3 closes. Power is now supplied to the critical load in the double conversion mode. It takes approximately 20 seconds for the UPS system to achieve the double conversion mode.

The UPS system is now operating in the double conversion mode and the green status indicator for normal operation is illuminated.

7.4.2 Shutting down a single UPS

A single UPS in the system can be shut down only if it is redundant. In practice, this means that a UPS is not allowed to be shut down if doing so would lead to an overload condition in the remaining UPSs in the system.

To shut down a single UPS:

1. In the home screen, press **Controls**.
The System controls screen is displayed.
2. In the System controls screen, press **UPS controls**.
3. In the UPS control screen, select **Shut down UPS**.

7.4.3 Enabling and disabling the battery charger

To turn the battery charger on or off, perform the following procedure:

1. In the home screen, press **Controls**.
The System controls screen appears.
2. In the System controls screen, press **UPS controls**.
3. Press the **Turn on / Turn off** button.

7.5 UPM control instructions

7.5.1 Starting the UPMs

Make sure that the load level does not exceed the single UPM capacity.

To start an individual power module in the double conversion mode:

1. Close the UPS input feeder circuit breaker.
2. Close the UPS bypass input feeder circuit breaker.
3. Wait for the UPS control panel to become active and indicate logic power.
4. In the home screen, press **Controls**.
The System controls screen is displayed.
5. In the System controls screen, check that the UPS status is shown as **SHUTDOWN**.
6. Check that there are no active alarms.
7. In the System controls screen, press **Module controls**.
The Select module screen is displayed.
8. Select the UPM you want to start.
The UPM control screen is displayed. The UPM status is shown as **SHUTDOWN**.
9. In the UPM control screen, select **Start module**.
10. Wait for the following messages to appear sequentially on the UPM status line:
READY
ACTIVE
The UPM rectifier and inverter turn on and the UPM transfers to the double conversion mode and supplies the critical load.

7.5.2 Shutting down the UPMs

A single UPM in the system can be shut down only if it is redundant. In practice, this means that a UPM is not allowed to be shut down if doing so would lead to an overload condition in the remaining UPMs or UPSs in the system.

To shut down a single UPM:

1. In the home screen, press **Controls**.
The System controls screen is displayed.
2. In the System controls screen, press **Module controls**.
The Select module screen is displayed.
3. Select the UPM you want to shut down.
4. In the UPM control screen, select **Shut down module**.

7.6 Using the Remote Emergency Power-off switch

A UPS emergency power-off is initiated by the EPO pushbutton switch. In case of an emergency, you can use this switch to control the UPS output. The EPO switch de-energizes the critical load and powers down the UPS immediately without asking for verification. The UPS, including the static bypass switch, remains off until it is restarted.

CAUTION



When the EPO switch is activated, all power to the critical load is lost. Use this feature only in case of emergency.



Note: The following instructions are for the EPO switch supplied by Eaton Corporation. If you are using a customer-supplied EPO switch, it may not activate in the same way. For operating instructions, see the documentation provided with the switch.

To use the EPO switch:

1. Press the EPO pushbutton switch.
The input, output, and bypass backfeed relays open, the battery breaker or disconnect is tripped, and the power module is turned off immediately, without asking for verification.

To restart the UPS after using the EPO pushbutton, reset the EPO switch and then follow the procedure in Section [7.3.1](#) or Section [7.3.2](#).

WARNING



Do not attempt to restart the system after using the EPO switch until the conditions for safe start-up have been confirmed.

7.7 Turning the UPS from the double conversion mode to the maintenance bypass mode

Only trained personnel who are familiar with the behavior and functions of the UPS are allowed to operate the internal MBS.

To turn the UPS to maintenance bypass:

1. Follow the normal start position:

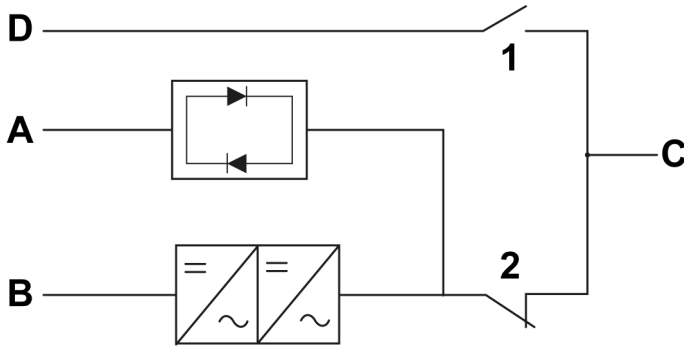

Figure 44. Normal positions of the switches

- | | |
|-------------------|--------------------------------------|
| A Bypass input | 1 Maintenance bypass (MBP) |
| B Rectifier input | 2 Maintenance isolation switch (MIS) |
| C UPS output | |
| D MBS input | |
2. Do the transfer from the double conversion mode to the bypass mode as instructed in Section 7.3.4. Remember to verify the transfer before proceeding to the next step.
 3. Remove the cover plate from front of the MBP and MIS.
 4. Turn on the maintenance bypass (MBP). This connects the feed from bypass input to the UPS output.
 5. Turn off the maintenance isolation switch (MIS). This disconnects the inverter and static bypass from the UPS output.
 6. Perform the LOAD OFF procedure as described in Section 7.3.8.
 7. Open the incoming feeder to disconnect the power from static bypass input terminals (X2)
 8. Open the incoming feeder to disconnect the power from rectifier input terminals X1.
 9. Open all battery breakers feeding the UPS battery input terminals X4.

The UPS is now in the maintenance bypass mode:

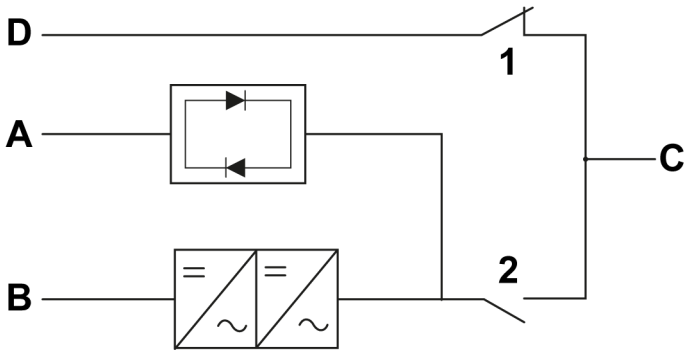

Figure 45. Maintenance bypass mode

- | | | | |
|---|----------------------|---|------------------------------------|
| A | Bypass input (X2) | 1 | Maintenance bypass (MBP) |
| B | Rectifier input (X1) | 2 | Maintenance isolation switch (MIS) |
| C | UPS output (X3) | | |
| D | MBS input (X8) | | |

7.8 Turning the UPS from the maintenance bypass mode to the double conversion mode

To turn the UPS back to the double conversion mode:

1. Follow the normal start position:

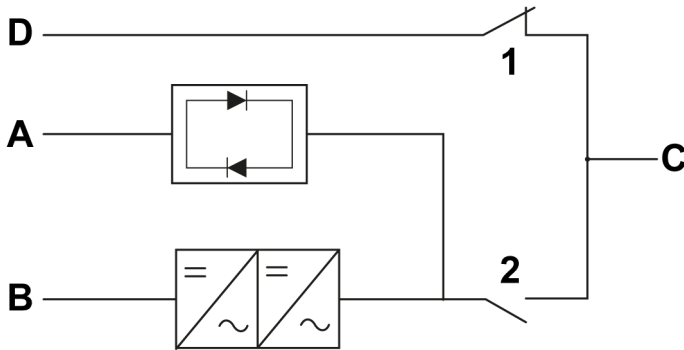

Figure 46. Maintenance bypass mode

- | | | | |
|---|-----------------|---|------------------------------------|
| A | Bypass input | 1 | Maintenance bypass (MBP) |
| B | Rectifier input | 2 | Maintenance isolation switch (MIS) |
| C | UPS output | | |
| D | MBS input | | |
2. Close the incoming feeder to connect the power to rectifier input terminals (X1).
 3. Close the incoming feeder to connect the power to static bypass input terminals (X2).
 4. Turn on the battery breakers feeding the battery terminals X4.
 5. Start the UPS system in the bypass mode
 - a. Make sure the UPS input and bypass (if dual feed) feeder circuit breakers are ON position.
 - b. In the home screen, select **Controls > System controls > Go to bypass**.
 6. Verify that there are no active alarms, and the UPS is on bypass mode.
 7. Turn on the maintenance isolation switch (MIS). This connects the inverter and static bypass to the UPS output.
 8. Turn off the maintenance bypass (MBP). This disconnects the feed from bypass input to the UPS output. The load is now supported by the static bypass.
 9. Install the cover plate to front of the MBP and MIS.
 10. Do the transfer from the bypass mode to the double conversion mode .
 - a. In the home screen, press Controls.
 - b. Select UPS controls (Single UPS) or System controls (UPS system).
 - c. Press Go online button. Confirm your selection.

The UPS is now in the double conversion mode.

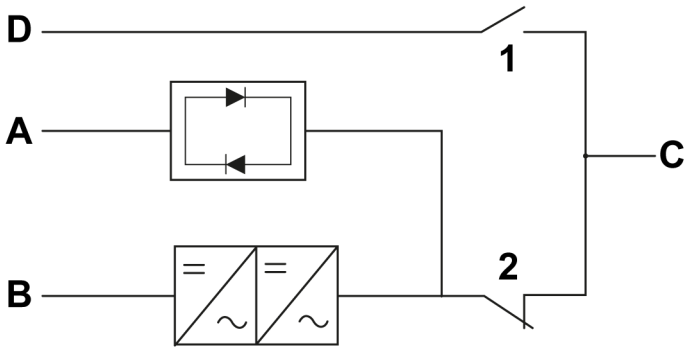

Figure 47. Normal positions of the switches

- | | |
|-------------------|--------------------------------------|
| A Bypass input | 1 Maintenance bypass (MBP) |
| B Rectifier input | 2 Maintenance isolation switch (MIS) |
| C UPS output | |
| D MBS input | |

8 UPS maintenance

The components inside the UPS cabinet are secured to a sturdy metal frame. All repairable parts and assemblies are located for easy removal with very little disassembly. This design allows authorized service personnel to perform routine maintenance and servicing quickly. Schedule periodic performance checks of your UPS system to keep it running properly. Regular routine checks of the operation and system parameters enable your system to function efficiently for many trouble-free years.

8.1 Important safety instructions

Remember that your UPS system is designed to supply power **EVEN WHEN IT IS DISCONNECTED FROM THE UTILITY POWER**. The UPS module interiors are unsafe until the DC power source is disconnected and the electrolytic capacitors are discharged.

After disconnecting the utility power and the DC power, authorized service personnel must wait at least 5 minutes for capacitor bleed-off before attempting internal access to the UPS module.

DANGER



LETHAL VOLTAGE. Do not operate the UPS system without the cabinet doors or protective panels secured. Do not make any assumptions about the electrical state of any cabinet in the UPS system.

WARNING



All service and maintenance work must be performed only by service personnel qualified and authorized by Eaton.

CAUTION



An additional warning label, shown in Figure 48, must be installed at the UPS input terminals and all the primary power isolators used to isolate the UPS unit if the UPS input is connected through external isolators that, when opened, isolate the neutral. These warning labels can be obtained from your local service representative.

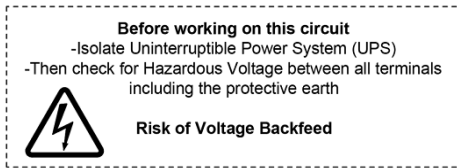

Figure 48. Warning label

Since each battery string is an energy source in itself, opening the battery circuit breaker does not de-energize the voltage within the battery string.



DANGER

Do not attempt to access any internal area of the battery string yourself. Voltages are always present in the battery strings. If you suspect that a battery string needs service, contact your service representative.

8.2 Performing preventive maintenance

The UPS system requires very little preventive maintenance. However, inspect the system periodically to verify that the units are operating normally and that the batteries are in good condition.

The majority of the service and maintenance work must be performed by service personnel qualified by Eaton. Only the actions described in Section [8.2.1](#) and Section [8.2.2](#) are allowed to be performed by the user.

8.2.1 Daily maintenance

Do this daily:

1. Examine the area surrounding the UPS system. Make sure that the area is not cluttered, allowing free access to the unit.
2. Examine that the air intakes (vents on the front door of the UPS cabinet) and the exhaust openings (at the rear of the UPS cabinet) are not blocked.
3. Make sure that the operating environment is within the parameters specified in Section [4.3.1](#) and Chapter [9](#).
4. Make sure that the UPS is in the normal mode (the normal mode status indicator is illuminated). If an alarm lamp is lit or the normal mode status indicator is not lit, contact an Eaton service representative.

8.2.2 Monthly maintenance

Do this once a month:

1. Examine the system parameters on the control panel (see Section [7.1.4](#)).

2. If the optional air filters are installed, examine them and wash or replace them, if needed. They are located behind the front doors. Contact your service representative for replacement filters. To replace the filters:
 - a. Open the UPS front door.
 - b. Replace the filters.
 - c. Close the UPS front door.
3. Record the check results and any corrective actions in a service log.

8.2.3 Periodic maintenance

Inspect the UPS system once a year to determine if components, wiring, and connections exhibit evidence of overheating. Pay particular attention to bolted connections. Bolted connections must be re-torqued periodically.

8.2.4 Annual maintenance

WARNING



Only authorized personnel that are familiar with the maintenance and servicing of the UPS system can do annual preventive maintenance. For more information about service offerings, contact your authorized Eaton Customer Service Engineer.

8.2.5 Battery maintenance

WARNING



Only authorized personnel can do the battery replacement and maintenance. If you need battery maintenance, contact your authorized Eaton Customer Service Engineer.

8.3 Recycling the used UPS or batteries

Remove the battery bank before disposing of the UPS or its battery cabinet. Obey the local requirements regarding battery recycling or disposal.

WARNING



Only authorized personnel can remove the batteries due to the risk caused by high energy and voltage.

Do not discard waste electrical or electronic equipment in the trash. For proper disposal, contact your local collecting/recycling/reuse or hazardous waste center and obey the local legislation.

The following symbols indicate a product requiring special handling:

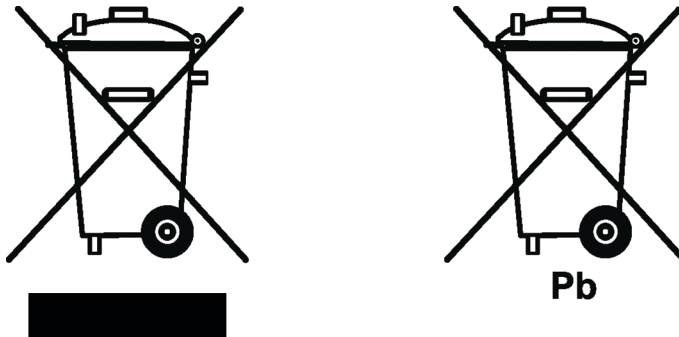

Figure 49. WEEE symbol (left) and battery recycling symbol

When handling waste from electrical and electronic equipment, use proper local collecting centers that meet local legislation.



WARNING

HAZARDOUS MATERIALS.

Batteries can contain high voltages and caustic, toxic and flammable substances. If used improperly, batteries can injure or kill people and damage equipment.

Do not discard of unwanted batteries or battery material in the public waste disposal system. Obey all the applicable local regulations regarding the storage, handling and disposal of batteries and battery materials.

8.4 Maintenance training

For more information about training and other services, contact your Eaton representative.

9 Technical data

For a complete technical specification, contact your Eaton representative. Due to continuous product improvement programs, specifications are subject to change without notice.

9.1 Directives and standards

Table 22: Directives and standards

Safety	IEC 62040-1: Uninterruptible power systems (UPS) - Part 1: General and safety requirements for UPS IEC 60950-1: Information technology equipment - Safety - Part 1: General requirements
EMC, emissions	IEC 62040-2: Uninterruptible power systems (UPS) - Part 2: Electromagnetic compatibility (EMC) requirements / Ed. 2
EMC, immunity	IEC 61000-2: Electromagnetic compatibility (EMC), IEC 61000-2-2 (Low-frequency conducted), IEC 61000-4-2 (ESD), IEC 61000-4-3 (RF electromagnetic field), IEC 61000-4-4 (Fast transient-burst), IEC 61000-4-5 (Surge), IEC 61000-4-6 (Conducted RF common mode), IEC 61000-4-8 (Power frequency magnetic field)
Performance & tests	IEC 62040-3: Uninterruptible power systems (UPS) - Part 3: Method of specifying the performance and test requirements
Environmental	IEC62040-4: Uninterruptible Power Systems (UPS) - Part 4: Environmental Aspects - Requirements and Reporting IEC 62430: Environmentally conscious design for electrical and electronic products
RoHS	2011/65/EU on the restriction of the use of certain hazardous substances in electrical and electronic equipment
WEEE	2012/19/EU on waste electrical and electronic equipment (WEEE)
ECO Design Directive	2009/125/EC establishing a framework for the setting of eco-design requirements for energy-related products
Batteries	2006/66/EC on batteries and accumulators and waste batteries and accumulators
Packaging	94/62/EC on packaging and packaging waste

9.2 UPS system input

Table 23: UPS system input

Rated input voltage	380 V; 400 V; 415 V
Voltage tolerance	400 V -15% / +20%
Rated input frequency	50 or 60 Hz, user configurable
Frequency tolerance	40 to 72 Hz
Number of input phases (rectifier & bypass)	3 phases, + N
Input power factor	10-25% load: 0.94 25-100% load: 0.99
Rated/maximum mains input current	See Tables 11, 12 and 13
Input current distortion at rated input current, iTHD	< 3%
Rectifier ramp-up, rectifier start and load step	10 A/s (default), configurable Minimum 1 A/s
Back feed protection	Yes, for rectifier and bypass lines

9.3 UPS system output

Table 24: System output for Eaton 93PM-xxx(500) UPS models

For further information, see Table 3.

Number of output phases	3 phases + N
Rated output voltage	380 V; 400 V; 415 V
Rated output frequency	50 or 60 Hz, user configurable
Total voltage harmonic distortion:	
100 % linear load	< 1.5%
100 % non-linear load	< 3%
Output frequency variation	±0.1 Hz
Slew rate	0.4 Hz/s
Output current	See Tables 11 and 12
Overload capability at ambient 35°C (on inverter)	60 s 101–105% load 10 s 106–125% load 300 ms > 125% load
Overload capability at ambient 35°C (in the stored energy mode)	60 s 100–105% load

Overload capability at ambient 35°C (in the bypass mode)	Continuous $\leq 115\%$ load 10 ms 1,000% load Note! Bypass fuses could limit the overload capability.
Load power factor (rated)	Nominal 0.9 or 0.95
Load power factor (permitted range)	From 0.8 lagging to 0.8 leading

Table 25: System output for Eaton 93PM-xxx(400) UPS models

For further information, see Table 2.

Number of output phases	3 phases + N
Rated output voltage	380 V; 400 V; 415 V
Rated output frequency	± 0.1 Hz
Total voltage harmonic distortion:	
100 % linear load	< 1.5%
100 % non-linear load	< 3%
Output frequency variation	50 or 60 Hz, user configurable
Slew rate	0.4 Hz/s
Output current	See Tables 11 and 12
Overload capability at ambient 40°C (on inverter)	10 min 101–110% load 60 s 111–125% load 10 s 126–150% load 300 ms > 150% load
Overload capability at ambient 40°C (in the stored energy mode)	10 min < 102-110% load 60 s 111-125% load 300 ms > 125% load
Overload capability at ambient 30 °C (in the bypass mode)	Continuous $\leq 115\%$ load 10 ms 1000% load Note! Bypass fuses could limit the overload capability.
Load power factor (rated)	Nominal 1.0
Load power factor (permitted range)	From 0.8 lagging to 0.8 leading

9.4 UPS environmental specifications

Table 26: UPS environmental specifications

Acoustic noise at 1 m	
------------------------------	--

Ambient UPS storage temperature range	From -25 °C ... +55 °C in the protective package Internal battery: +20 °C ... +25 °C in the protective package
Ambient operating temperature range, Eaton 93PM-xxx(400) models	From +0 °C ... +40 °C*
Ambient operating temperature range, Eaton 93PM-xxx(500) models	From +0 °C ... +35 °C
Relative humidity range	5 to 95%, no condensation allowed
Maximum service altitude	1,000 m (3,300 ft) above sea level at +40 °C Maximum 2,000 m (6,600 ft) with 1% derating per each additional 100 m above 1,000 m.
Maximum storage time with internal batteries	6 months without discharge
*) The maximum recommended operating and storage temperature for UPS with internal batteries is +25 °C. Higher storage temperature shortens the maximum storage time without recharging.	

9.5 Battery specification

Table 27: Battery specification

Battery type	VRLA, 12 VDC
Battery quantity	Eaton 93PM-xxx(500) models: 40 blocks, 240 cells per battery string Eaton 93PM-xxx(400) models: 40 blocks, 240 cells per battery string. Supported range 36...40 blocks (216...240 cells) per string. Note: Do not connect battery strings with different battery quantity and voltage in parallel!
Battery voltage	432 V (36 blocks) or 480 V (40 blocks)
Recharge profile	ABM or float charge
End of discharge voltage	1.67 VPC to 1.75 VPC, configurable or automatic (load adaptive)
Compatibility	- Wet-cell batteries - Lithium-ion batteries - Supercapacitors

Charge current	
Eaton 93PM-xxx(500) models	9 A per UPM, full load 29 A per UPM, load < 40 kVA per UPM
Eaton 93PM-xxx(400) models	16 A per UPM, full load 29 A per UPM, load < 40 kW per UPM
Note that the maximum charge current is 29 A per UPM.	
Battery start option	Yes



Note: For external battery connection, 24 Vdc Shunt Trip signal wiring from the UPS must be connected to the auxiliary signal connection of the battery breaker.

10 Warranty

10.1 General

The product is warranted against defects in materials and workmanship for a period of twelve (12) months from its original date of purchase. The local office or distributor may grant a warranty period different to the above. Please refer to local terms of liability as defined in the supply contract.

The UPS manufacturer is not responsible for:

- Any costs resulting from a failure if the installation, commissioning, repair, alteration, or ambient conditions of the equipment do not fulfill the requirements specified in the documentation delivered with the unit and other relevant documentation.
- Equipment subjected to misuse, negligence or accident.
- Equipment comprised of materials provided or designs stipulated by the purchaser.

The warranty is only valid if the installation inspection and initial startup of the UPS unit is carried out by an authorized Eaton Customer Service Engineer or by other qualified service personnel authorized by Eaton. Service and maintenance of the UPS shall also be performed only by an authorized Eaton Customer Service Engineer or by other qualified service personnel authorized by Eaton. Otherwise the warranty will be voided.

If the product fails to meet its published specifications due to a defect in material and workmanship, covered by this warranty, the seller will repair or replace the warranted product. Such repair or replacement will be made by Eaton or by a service provider approved by Eaton. Repair or replacement during the warranty period does not extend the original warranty. Warranty does not cover taxes, which will be due in connection with replacement or repair of the product.

Batteries are warranted against failures in material and workmanship, not against the normal aging and reduction of ampere-hour capacity. The product storage environment has to meet manufacturer's specifications, failure to do this will cause the warranty to be voided.

Under no circumstances shall the manufacturer, its suppliers or subcontractors be liable for special, indirect, incidental or consequential damages, losses or penalties.

The technical data, information and specifications are valid at the time of printing. The UPS manufacturer reserves the right to modifications without prior notice.

10.2 Whom to contact in case of Warranty

In case of Warranty, or while unsure if the unit in question is covered by warranty, contact the respective sales organization where the unit was purchased. Have the following information available:

- Purchase order number and purchase order date
 - Installation date
- OR
- Serial number and part number of the unit (information available on the unit's label)

Appendix A: Relay Alarms

Name	ID
24V Power Supply Failed	73
5V Power Supply Failed	72
ABM Active	232
ABM Enable	231
ABM Installed	230
ABM State Reset	91
ABM State Charging	88
ABM State Floating	89
ABM State Resting	90
Adaptive Overload Capacity Off	116
Adaptive Overload Capacity Off	326
Alternate Sync (Sync Box)	317
Alternate Sync Error	318
Ambient Over Temperature	94
Auto calibration in progress	321
Automatic Start Up Pending	263
Backfeed Switchgear Closed	203
Backfeed Switchgear Failed	204
Batteries Disconnected	50
Battery Backup Power Failure	458
Battery Breaker Open/Closed	102
Battery Breaker Open/Closed	322
Battery Current Over Limit	12
Battery DC Over Voltage	19
Battery DCUV Trip Imminent	107
Battery Discharging	61
Battery In Common	25
Battery Installed	63
Battery Installed	209
Battery Over Temperature Trip	93
Battery Over Temperature	92
Battery Startup Failure	108
Battery Switchgear Failed	70
Battery Switchgear Open/ Closed	64
Battery Test Aborted	460
Battery Test Failed	46

Name	ID
Battery Test In Progress	60
Battery Test Cancel Command	439
Battery Test Command	438
Boost Charging Active	327
Boost Charging Available	328
Boost Charging Installed	330
Bypass AC Over Voltage	192
Bypass AC Under Voltage	193
Bypass Breaker Active	278
Bypass Breaker Installed	277
Bypass Command	385
Bypass Hot	206
Bypass Installed	207
Bypass Not Available	202
Bypass Over Temperature	290
Bypass Over Temperature Trip	319
Bypass Phase Rotation	201
Bypass Service Button On	315
Bypass Sync Out of Range	268
Bypass Under/ Over Frequency	194
Charger Failed	84
(UPM received) Charger Off Command	41
Charger Off Command (issued from CSB)	437
Charger On Command (issued from CSB)	436
Charger On Command	42
Charger On/Off	56
Check CSB EEPROM	419
Check Pull Chain	82
Check Pull Chain	235
Check System Type Configuration Error	461
Chimney Ambient Over Temperature	303
Chimney Fan Failed	304
Clear Alarms	421
Clear Call Service	422
Clear Maintenance Reminder	424
Clear Status Command	450
Clear Warranty Reminder	423
Clock Set Done	427

Name	ID
Command Received	294
Configuration Error	53
CSB Control Power	425
CSB EEPROM Version Downgrade	464
CSB Software Incompatible	426
DC Link Over Voltage	10
DC Link Under Voltage	11
Disable ABM Command	447
Disable ESS Command	444
Disable HRS Command	456
Disable Service Mode Command	441
Disable VMMS Command	446
Distributed Parallel System	276
ECT Command (UPM)	86
ECT Command	257
Emergency Transfer to Bypass	241
Enable ABM Command	448
Enable Auto Calibration Command	462
Enable ESS Command	444
Enable High Alert Command	459
Enable HRS Command	457
Enable Service Mode Command	440
Enable VMMS Command	446
ESS Active	213
ESS Enabled	226
ESS Installed	225
ESS Inverter Gapping	5
ESS Not Available	307
Exit ECT Mode Abnormally	80
Exit ESS Mode	205
External CAN Abnormal or Configuration Mismatch	265
External communications failure	463
Fan Failed	48
Fan Power Board Cool Fan Failed	305
Frequency Auto Detected	309
Fuse Failed	47
Ground Wiring Fault	264
High Alert	308

Name	ID
Horn is Buzzing	418
HRS Active	283
HRS Enabled	282
HRS Installed	281
I2C Bus Failed	115
Input AC Over Voltage	2
Input AC Under Voltage	3
Input Sync Out of Range	75
Input Sync Out of Range	269
Input Under/ Over Frequency	4
Internal CAN Bus Failed	109
Internal CAN Bus Failed	310
Internal Communications Failure	414
Internal Redundant System	275
Inverter AC Over Voltage	1
Inverter AC Under Voltage	0
Inverter Fault	7
Inverter Matched to Output	105
Inverter On/Off	23
Inverter Output Over Current	9
Inverter Over Temperature	6
Inverter Over Temperature Trip	68
Inverter Overload Trip	71
Inverter Startup Failure	76
Inverter Switchgear Closed	62
Inverter Switchgear Failed	67
Load Off Command	386
Load Off Command	223
Load Power Off	297
Loss of Sync Bus	79
Loss of PWM Sync	114
Low Battery Shutdown	43
Low Battery Warning	15
Maintenance Out of Date	428
MBS Installed	208
MCU 24V Power Supply Failed	255
MCU 5V Power Supply Failed	254
MCU Configuration Error	239

Name	ID
MCU Control Power	289
MCU EEPROM Checksum Failed	240
MCU Software Incompatible	210
MIS Installed	291
MIS Open/Closed	292
MOB Open	279
Not Enough Bypass Capacity	272
Not Enough Redundant UPMs	323
Not Enough UPMs	271
On Alarm LED Is Lit	416
On Battery LED Is Lit	260
On Bypass LED Is Lit	261
On MBS, Battery	216
On MBS, ESS Active	298
On MBS, HRS Active	300
On MBS, On Bypass	218
On MBS, Starting	296
On MBS, Shutdown	219
On MBS, Unit Online	217
On MBS, VMMS Active	299
On Notice LED Is Lit	417
On Line LED Is Lit	262
Online command	384
Output AC Over Voltage	99
Output AC Over Voltage	196
Output AC Under Voltage	100
Output AC Under Voltage	195
Output Hot	236
Output Not In Sync With Bypass	286
Output Not In Sync with Ext Sync	287
Output Overload Trip	302
Output Phase Rotation	199
Output Sync Out of Range	267
Output Under/ Over Frequency	197
Output Voltage Abnormal	198
Parallel Meters CAN Bus Failed	415
Parallel Setup Failure	258
Parameter Match Failed	316

Name	ID
Phase A Overload	27
Phase B Overload	28
Phase C Overload	29
PhaseA Overload Level2	30
PhaseA Overload Level3	33
PhaseA Overload Level4	36
PhaseB Overload Level2	31
PhaseB Overload Level3	34
PhaseB Overload Level4	37
PhaseC Overload Level2	32
PhaseC Overload Level3	35
PhaseC Overload Level4	38
Precharge Failed	54
Pull Chain	81
Pull Chain	234
Pull Out Not Allowed	112
Rectifier Breaker Open	18
Rectifier Fault	104
Rectifier Input Over Current	8
Rectifier On/Off	55
Rectifier Over Temperature	52
Rectifier Over Temperature Trip	69
Rectifier Phase Rotation	21
Rectifier Startup Failure	66
Rectifier Switchgear Open/Closed	78
Remote Emergency Power Off	200
Reset Alarms Command	449
Reset History LOG	420
Restart Command	435
Service Battery	26
Service Required	453
Shutdown Command	434
Shutdown Imminent	237
Signal Input 1 On	407
Signal Input 2 On	408
Signal Input 3 On	409
Signal Input 4 On	410
Signal Input 5 On	411

Name	ID
Signal Input 6 On	412
Signal Input 7 On	413
Signal Input 8 On	451
Signal Input 9 On	452
Signal Input Battery Disconnected	402
Signal Input Bypass Sync Disabled	400
Signal Input Charger Off	392
Signal Input Disable Battery Charge and Discharge	401
Signal Input Forced Maintenance Bypass	404
Signal Input Maintenance Bypass	403
Signal Input MIS Open	406
Signal Input MOB Open	405
Signal Input On Generator	397
Signal Input Remote ESS Command	395
Signal Input Remote Go to Bypass	389
Signal Input Remote Load Off	390
Signal Input Remote Power Module Off	391
Signal Input Remote Rectifier Off	398
Signal Input Remote Sync	399
Signal Input Remote UPS On	388
Signal Input Remote VMMS Command	394
Signal Input Remote VMMS/ESS Off	393
Signal Input Reset Alarms	396
Signal Input Transformer Over Temperature	465
Signal Input	331
Single UPS System	274
Site Wiring Fault	49
Site Wiring Fault	284
SPI Bus Failed	77
SPI Bus Failed	266
Start Boost Charge Command	470
Start ECT Command	454
Static Switch Active	280
Static Switch On	430
Static Switch Short	224
Stop Boost Charge Command	471
Stop ECT Command	455
STS Ambient Over Temperature	301

Name	ID
STS Fan Failed	288
System Not Redundant	233
System On Bypass	312
System On Maintenance Bypass	270
System Overload	311
System Test in Progress	259
To Bypass Command	221
Too Many EEP Written Operation	468
Too Many Inverter Transfers	65
Too Many Inverter Transfers	285
Too Many Battery Transfers	106
Transformer Fan Failed	324
Transformer Over Temperature Trip	325
Turn Off Battery Command	433
Turn to Battery Command	432
UPM Command	83
UPM Connection Fail	111
UPM Control Power	22
UPM Critical Parameters Sync In Process	113
UPM EEPROM Checksum Failed	13
UPM Hardware ID Mismatching	320
UPM Hot	24
UPM in Service Mode	97
UPM Normal, On ESS Mode	95
UPM Normal, On VMMS	96
UPM Not Responding	367
UPM Off Command	40
UPM On Battery	58
UPM On Command	323
UPM On ECT	87
UPM On Normal	59
UPM On Command	39
UPM Remote Emergency Power Off	45
UPM Selective Trip	51
UPM Shutdown Imminent	14
UPM Software Incompatible	44
UPM State Request	57
UPM Test Command	378

Name	ID
UPM Unlock	110
UPMs Not Redundant	314
UPS Exit ECT Process	306
UPS Normal Command	222
UPS Not Redundant	313
UPS On Battery	215
UPS On Bypass	211
UPS On Generator	220
UPS PhaseA Output Overload	242
UPS PhaseA Overload Level2	245
UPS PhaseA Overload Level3	248
UPS PhaseA Overload Level4	251
UPS PhaseB Output Overload	243
UPS PhaseB Overload Level2	246
UPS PhaseB Overload Level3	249
UPS PhaseB Overload Level4	252
UPS PhaseC Output Overload	244
UPS PhaseC Overload Level2	247
UPS PhaseC Overload Level3	250
UPS PhaseC Overload Level4	253
UPS Ready	238
UPS Shutdown	212
UPS Starting	293
UPS System Off	273
UPS System Online	214
Utility Not Available	16
Warranty Out of Date	429
VMMS Not Available	256
VMMS Active	229
VMMS Enable	228
VMMS Installed	227



Powering Business Worldwide

Eaton Power Quality Oy
Koskelontie 13
FI-02920 Espoo, Finland
www.eaton.eu

Copyright © 2018 Eaton Corporation plc. All rights reserved. Unauthorized copying and lending are prohibited.